



8410 IP Display Speaker / 8420 IP Dual-Sided Display Speaker

User Guide



Information Notices

**Warning**

Warning indicates a potentially hazardous situation which, if not avoided, could result in death or serious injury

**Caution**

Caution indicates a potentially hazardous situation which, if not avoided, could result in minor or moderate injury and/or damage to the equipment or property

**Important**

Important indicates a key piece of updates, information, and instructions that need to be followed for correct and safe use of the device

**Note**

Note indicates useful updates, information, and instructions that should be followed

**Tips & Tricks**

Tips & Tricks indicate helpful instructions that could help you with your device

Disclaimer

The information contained in this document is believed to be accurate in all respects but is not warranted by Algo. The information is subject to change without notice and should not be construed in any way as a commitment by Algo or any of its affiliates or subsidiaries. Algo and its affiliates and subsidiaries assume no responsibility for any errors or omissions in this document. Revisions of this document or new editions of it may be issued to incorporate such changes. Algo assumes no liability for damages or claims resulting from any use of this manual or such products, software, firmware, and/or hardware.

No part of this document can be reproduced or transmitted in any form or by any means – electronic or mechanical – for any purpose without written permission from Algo.

For additional information or technical assistance in North America, please contact Algo's support team:

Algo Technical Support

1-604-454-3792

support@algosolutions.com

Table of Contents

1	General	7
1.1	Introduction	7
1.1.1	Key Features.....	7
2	Setup and Installation For 8410 and 8420	8
2.1	8410 Mounting & Installation	8
2.1.1	Getting Started – Quick Install and Setup	8
2.1.2	Installation	8
2.2	8420 Mounting & Installation	10
2.2.1	Getting Started – Quick Install & Test	10
2.2.2	Installation	10
2.3	Making Your First Configuration	11
2.4	Power Requirements.....	12
2.5	Reset.....	12
3	Applications	13
3.1	Voice Paging	13
3.2	Notification.....	13
3.3	Visual Communication	13
3.4	Multicast Receiver.....	13
3.5	Scheduling	13
3.6	InformaCast Compatible	13
4	Features.....	14
4.1	Setting Up Visual Display Content.....	14
4.2	SIP Paging: One 8410	14
4.3	Multicast Overview	15
4.3.1	SIP Paging: Multiple 8410s (Using Multicast)	15
4.3.2	SIP Paging: Multiple Display Speakers (Using Individual SIP extensions)	15
4.4	SIP-Activated Visual Notification Alerts	16
4.5	Color TLS for SIP Signaling and Provisioning	16
5	Web Interface.....	21
5.1	Stats.....	21
5.1.1	Device Status	21
5.2	Basic Settings.....	22
5.2.1	SIP	22
5.2.2	Features.....	25
5.2.3	Multicast.....	28
5.3	Multicast (Transmitter/Sender Settings)	30
5.4	Multicast (Receiver Settings)	33
5.5	Display	35

5.5.1	Screens.....	35
5.5.2	Slides.....	37
5.5.3	Data	39
5.6	Additional Features	40
5.6.1	Input/Output	40
5.6.2	Emergency Alerts.....	46
5.6.3	More Page Extensions	50
5.6.4	More Ring Extensions	51
5.7	Advanced Settings	52
5.7.1	Network	52
5.7.2	Admin	56
5.7.3	Users	61
5.7.4	Time	61
5.7.5	Provisioning	63
5.7.6	Advanced Audio.....	66
5.7.7	Advanced SIP	68
5.7.8	Advanced Multicast	72
5.8	System	74
5.8.1	Maintenance.....	74
5.8.2	Firmware.....	75
5.8.3	File Manager	77
5.8.4	Tones	78
5.8.5	System Log.....	78
5.9	Logout.....	78
6	Specifications.....	79
7	FCC Compliance Statement	83

Tables

Table 1: 8410 Specification Table	79
Table 2: 8420 Specification Table	81

Figures

Figure 1: 8410 Status.....	21
Figure 2: 8410 Basic Settings → SIP	23
Figure 3: 8410 Basic Settings → Features.....	26
Figure 4: Multicast transmitter mode settings	30
Figure 5: Multicast receiver mode settings.....	33
Figure 6: Input settings	40
Figure 7: 1203 Call Switch	41

Figure 8: 1202 Call Button – the insert card is interchangeable.....	41
Figure 9: 1204 Volume Control	42
Figure 10: Emergency Alerts	46
Figure 11: More page extensions.....	50
Figure 12: More ring extensions - screen options	51
Figure 13: Network settings	52
Figure 14: Admin settings	57
Figure 15: Users settings	61
Figure 16: Time settings	61
Figure 17: Provisioning settings	63
Figure 18: Advanced audio settings	66
Figure 19: Advanced SIP Setting.....	68
Figure 20: Advanced multicast - transmitter settings.....	72
Figure 21: Maintenance settings.....	74
Figure 22: Firmware settings.....	75
Figure 23: File manager settings	77
Figure 24: Tones settings	78
Figure 25: System log settings.....	78

IMPORTANT WARNING AND SAFETY INFORMATION



Important Notice

This product is powered by a certified limited power source (LPS), Power over Ethernet (PoE); through CAT5 or CAT6 connection wiring to an IEEE 802.3at / 802.3bt compliant network PoE switch. The product is intended for installation indoors. All wiring connections to the product must be in the same building. If the product is installed beyond the building perimeter or used in an inter-building application, the wiring connections must be protected against overvoltage/transient. Algo recommends that this product is installed by a qualified electrician.

If you are unable to understand the English language safety information, then please contact Algo by email for assistance before attempting an installation support@algosolutions.com.



Consignes de Sécurité Importantes

Ce produit est alimenté par une source d'alimentation limitée certifiée (alimentation par Ethernet); des câbles de catégorie 5 et 6 joignent un commutateur réseau à alimentation par Ethernet homologué IEEE 802.3at / 802.3bt Le produit est conçu pour être installé à l'intérieur. Tout le câblage rattaché au produit doit se trouver dans le même édifice. Si le produit est installé au-delà du périmètre de l'édifice ou utilisé pour plusieurs édifices, le câblage doit être protégé des surtensions transitoires. Algo recommande qu'un électricien qualifié se charge de l'installation de ce produit.

Si vous ne pouvez comprendre les consignes de sécurité en anglais, veuillez communiquer avec Algo par courriel avant d'entreprendre l'installation au support@algosolutions.com.



Información de Seguridad Importante

Este producto funciona con una fuente de alimentación limitada (Limited Power Source, LPS) certificada, Alimentación a través de Ethernet (Power over Ethernet, PoE); mediante un cable de conexión CAT5 o CAT6 a un conmutador de red con PoE en cumplimiento con IEEE 802.3at / 802.3bt. El producto se debe instalar en lugares cerrados. Todas las conexiones cableadas al producto deben estar en el mismo edificio. Si el producto se instala fuera del perímetro del edificio o se utiliza en una aplicación en varios edificios, las conexiones cableadas se deben proteger contra sobretensión o corriente transitoria. Algo recomienda que la instalación de este producto la realice un electricista calificado.

Si usted no puede comprender la información de seguridad en inglés, comuníquese con Algo por correo electrónico para obtener asistencia antes de intentar instalarlo: support@algosolutions.com.



Wichtige Sicherheitsinformationen

Dieses Produkt wird durch eine zertifizierte Stromquelle mit begrenzter Leistung (LPS – Limited Power Source) betrieben. Die Stromversorgung erfolgt über Ethernet (PoE – Power over Ethernet). Dies geschieht durch eine Cat-5-Verbindung oder eine Cat-6-Verbindung zu einer IEEE 802.3at / 802.3bt-konformen Ethernet-Netzwerkweiche. Das Produkt wurde konzipiert für die Installation innerhalb eines Gebäudes. Alle Kabelverbindungen zum Produkt müssen im selben Gebäude bestehen. Wenn das Produkt jenseits des Gebäudes oder für mehrere Gebäude genutzt wird, müssen die Kabelverbindungen vor Überspannung und Spannungssprüngen geschützt werden. Algo empfiehlt das Produkt von einem qualifizierten Elektriker installieren zu lassenv.

Sollten Sie die englischen Sicherheitsinformationen nicht verstehen, kontaktieren Sie bitte Algo per Email bevor Sie mit der Installation beginnen, um Unterstützung zu erhalten. Algo kann unter der folgenden E-Mail-Adresse erreicht werden: support@algosolutions.com.

安全须知

本产品由认证的受限电源(LPS), 以太网供电(PoE), 通过 CAT5 或 CAT6 线路联接至 IEEE 802.3at / 802.3bt 兼容的 PoE 网络交换机供电。本产品适用于室内或建筑物周边安装。所有联接本产品的线路必须源自同一建筑物。本产品如需用于超出建筑物周边范围或跨建筑物的安装, 线路联接部分必须有过压和瞬态保护。Algo 建议本产品由专业电工安装。

如果您对理解英文版安全须知有问题, 安装前请通过电子邮件和 Algo 联系. support@algosolutions.com.

INSTALLATION

An improperly installed 8410 IP Display Speaker or 8420 IP Dual-Sided Display Speaker could fall from a wall or ceiling and cause serious injury or death.

Local building code may require one or more additional safety measure(s), particularly in earthquake prone regions.

EMERGENCY COMMUNICATION

If used in an emergency communication application, the 8410 IP Display Speakers and 8420 IP Dual-Sided Display Speaker should be routinely tested. SNMP supervision is recommended for assurance of proper operation. Contact Algo for other methods of operational assurance.

DRY INDOOR LOCATION ONLY

The 8410 IP Display Speaker and 8420 IP Dual-Sided Display Speaker is intended for dry indoor locations only. For outdoor locations, Algo offers weatherproof speakers and strobe lights.

CAT5 or CAT6 connection wiring to an IEEE 802.3at (PoE+) or IEEE 802.3 bt (PoE++) compliant network PoE switch must not leave the building perimeter without adequate lightning protection.

No wiring connected to the 8410 IP Display Speaker and 8420 IP Dual-Sided Display Speaker may leave the building perimeter without adequate lightning protection.

1 GENERAL

1.1 Introduction

Algo's 8410 IP Display Speaker is a SIP-compliant notification device that comprises of three core components – LCD screen, Wideband Speakers, and LED flashers – to create highly flexible and effective visual and audible communication. The combined functionality of the LCD display screen, speakers, and flashing LEDs enable voice paging, visual or audible alerting, and informational visual content, such as scrolling text messages, visual paging, images, or wayfinding. Two-way communication can also be established through the embedded microphone so real-time updates can easily be provided to admin staff. When idle, the Display Speakers can display an image, a clock face (shown in analog and/or digital format and synchronized to network time protocol (NTP)), rotating through a variety of announcements, or go to sleep.

The 8420 IP Dual-Sided IP Display Speaker has all the core components of the 8410 but double. The two-sided functionality of the 8420 is ideal for installation in corridors, large spaces, or hallways for easy opposite-facing visual and audible communication.

As 3rd-party, SIP-compliant devices, the 8410/8420 is designed to seamlessly integrate into most leading IP-based UC and Mass Notification platforms. The 8410/8420 is easily configured using central provisioning features or by accessing the web interface using your choice of browser.

1.1.1 Key Features

LCD Screen

The primary element of the 8410/8420 is the LCD screen(s). With nearly unlimited visual possibilities, the screen can produce scrolling text, flashing announcements, full-color images, or times and dates. Combined with LED backlighting and wide-angle viewing, the visual display can be seen from anywhere in a room or along a hallway. It can be customized to complement an audio announcement or to bring communication to an audio-less environment.

Speakers

For audible alerting and voice paging, the 8410/8420 offers similar functionality and voice quality to other Algo IP speakers, delivering wideband HD voice for clear voice communication and attention-grabbing audible alerting. An embedded microphone is included to enable ambient noise response and talkback capabilities.

LED Flashers

The LED flashers provide additional awareness for important messages. This can help draw attention to the screen, helping hearing-impaired audiences to notice the screen or bring awareness to audio-less environments.

2 SETUP AND INSTALLATION FOR 8410 AND 8420



Important

This guide provides important safety information which should be read thoroughly before permanently installing the product.

See the appropriate section below for mounting either the 8410 or 8420.

2.1 8410 Mounting & Installation

Algo's 8410 IP Display Speaker is a one-sided product intended for flush mounting on a wall. For the ceiling-mount option more suited to hallways, see the 8420 mounting and installation instructions below.

What is Included

The following items are included with the purchase of this device:

- 8410 IP Display Speaker
- Wall-mount bracket
- Bracket attachment screws (4x 6-32 Flat Head Hex Drive Machine Screws)
- Terminal Block Plug
- 5/64" Drive Size Allen Key
- Getting Started Sheet

What is Not Included

The following items are not included with the purchase of this device:

- Ethernet Cable
- PoE++ Switch
- Wall bracket screws (#8 screws required as appropriate for your wall)

2.1.1 Getting Started – Quick Install and Setup

1. Connect the 8410 to an IEEE 802.3at / 802.3bt compliant PoE+ or PoE++ network switch or power injector. See section 2.4 Power Requirements.
 - The green LED flashers will activate and a small blue light on the bottom below the flasher will remain on until boot up is completed – about 30 seconds.
 - After a few moments, the screen will show the Algo logo.
2. Once the unit finishes booting, a configuration message with the IP address will appear on the screen if it is in factory default state. *If there is no DHCP server, the 8410 will default to the static IP address 192.168.1.111.*



Note

If the IP address does not appear on the screen, press the reset (RST) button to hear the IP address recited over the speakers. The IP address will be repeated over the speakers until the reset button is pressed again to turn off.

3. Access the 8410 IP Display Speaker web interface by entering the IP address into a browser and login using the default password **algo**.

2.1.2 Installation

The 8410 IP Display Speaker is designed to fit on a wall bracket. Concealed wiring may enter from the wall into the wiring cavity. Alternatively, surface wiring may enter through a channel from the bottom edge.

Mounting the wall bracket securely:

1. Use four #8 wall bracket screws to hang the wall bracket. The wall-mount bracket should be secured to a stud to prevent the 8410 from falling.

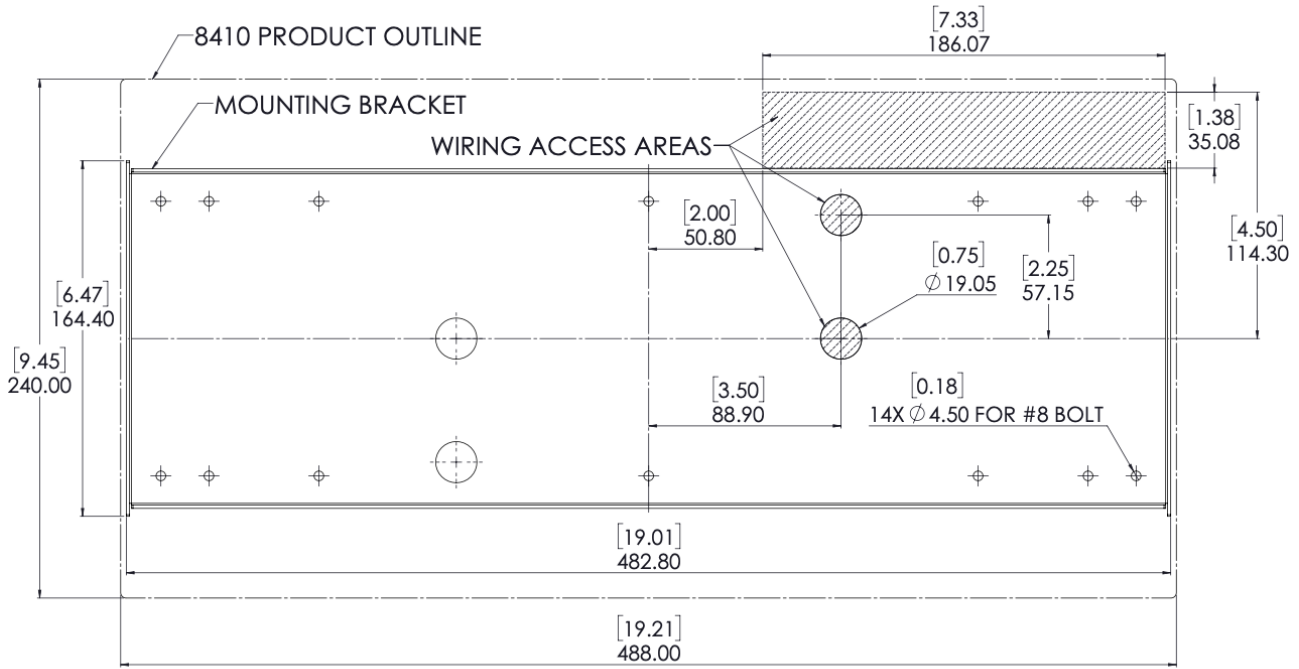

Attaching the 8410 to the wall-mount bracket:

1. Set the 8410 into the wall-mount bracket.
2. Align the holes on the side of the 8410 to the holes in the wall-mount bracket and tighten the four 6-32 mounting screws securely using the Allen key.

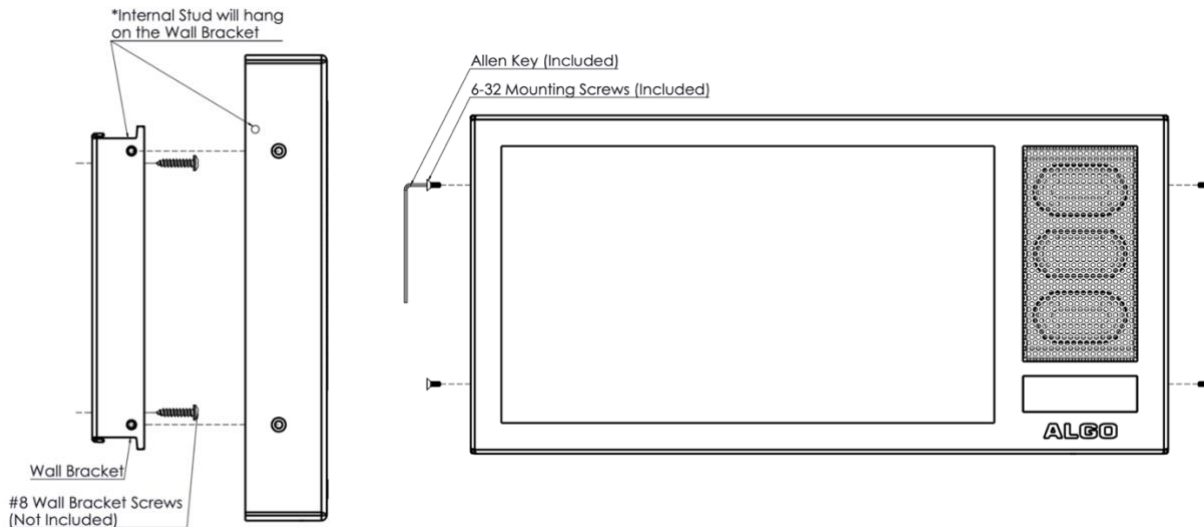

2.2 8420 Mounting & Installation

Algo's 8420 IP Dual-Sided Display Speaker is a two-sided SIP-compliant notification device that can be mounted on the ceiling or wall for two-sided visual communication. This is ideally suited for hallways, corridors, or open spaces.

What is Included

The following items are included with the purchase of this device:

- 8420 IP Display Speaker
- Mounting Bracket
- Mounting screws to attach device to mounting bracket (6x 10-32 screws, 2x 10-32 flat head screws Hex Drive Machine Screws)
- Terminal Block Plug
- 1/8" Drive Size Allen Key
- Getting Started Sheet
- Snap-On Ferrite for Ethernet Cable

What is Not Included

The following items are not included with the purchase of this device:

- Ethernet Cable
- PoE++ Switch
- Mounting screws to attach mounting bracket to wall or ceiling (recommended mounting hardware outlined in this guide)

2.2.1 Getting Started – Quick Install & Test

1. Connect the 8420 to an IEEE 802.3at / 802.3bt compliant PoE+ or PoE++ network switch or power injector. See section 2.4 Power Requirements.
 - The green LED flashers will activate and a small blue light on the bottom below the flasher will remain on until boot up is completed – about 30 seconds.
 - After a few moments, the screens on either side will show the Algo logo.
2. Attach the snap-on ferrite to the ethernet cable close to the connector to meet FCC requirements.
3. Once the unit finishes booting, a configuration message with the IP address will appear on each screen if it is in factory default state. If there is no DHCP server, the 8420 will default to the static IP address 192.168.1.111.



Note

If the IP address does not appear on the screen, press the reset (RST) button to hear the IP address recited over the speakers. The IP address will be repeated over the speakers until the reset button is turned off.

4. Access the 8420 IP Dual-Sided Display Speaker web interface by entering the IP address into a browser and login using the default password **algo**.

2.2.2 Installation

The 8420 IP Dual-Sided Display Speaker is designed to be both ceiling and wall mounted. Wiring enters through an opening in the hollow bracket for this product (see info in the Note after bullet 1 below).

Mounting the bracket securely to the wall/ceiling:

1. Mount the bracket securely to a wall or ceiling. Because the material you mount the device into may differ, see below for specific wall or ceiling mount instructions by material type.

Note: *Wires can be routed into the hollow tubes of the bracket from the wall/ceiling or through the wire feed hole outside the tube. Wire must be routed on the same side as the speakers to match the connection area.*

1. Set the 8420 into the mounting bracket by partially threading the screws into the holes next to the connector opening and mount the screws through the larger hole of the keyhole slot. Slide the 8420 into the smaller holes to lock the device in place.
2. Slide the ceiling- or wall-mount connector cover into place.
3. Fasten all six mounting screws on the bracket and the two flat mounting screws on the connector cover.

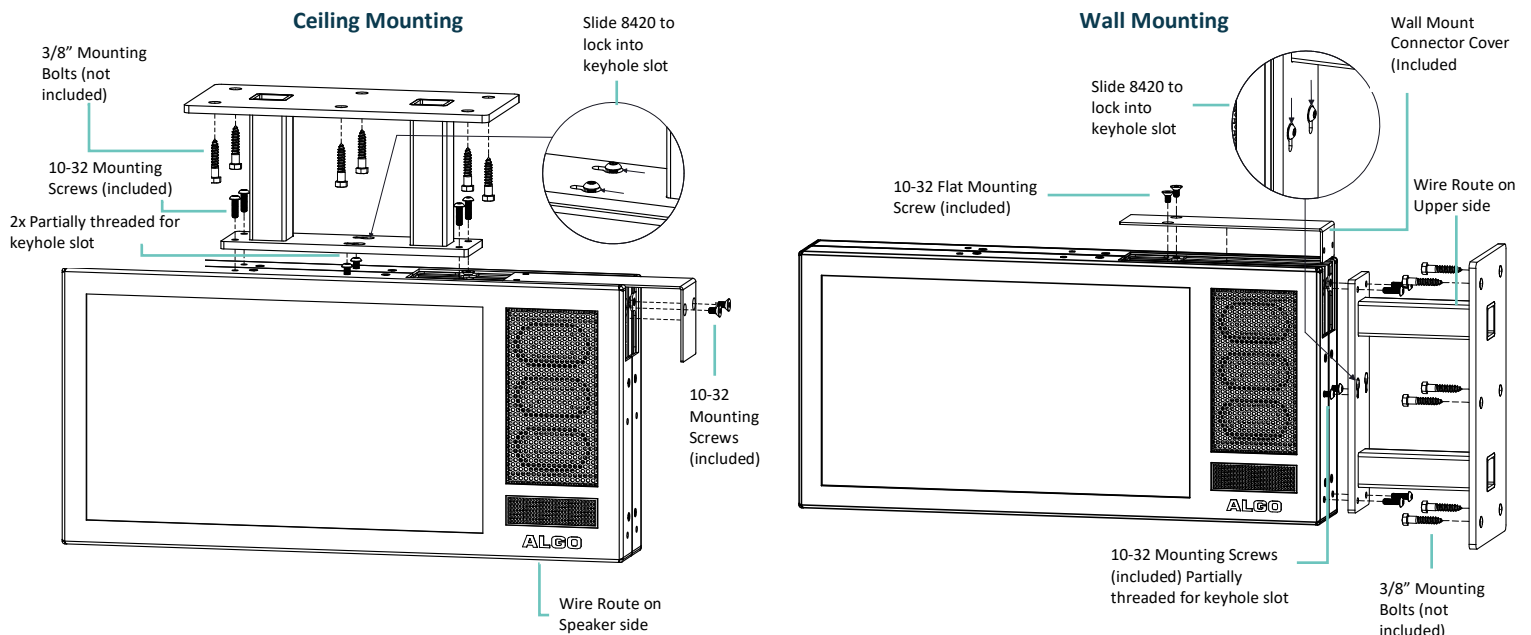

8420 Wall Mount

- For concrete, brick, or block install, use 6 x 5/16" x 1 5/8" female threaded anchors rated for 200 lbs each or greater pull and install bracket using 6 x 1 1/2" grade 5 threaded bolts with flat washer.
- For plaster or drywall install, use 6 x 5/16" toggle bolts and washers rated for 60 lbs each or greater. The bolts with a washer should be fed through the bracket prior to attaching toggles. If a wood stud is available and the position is known, use 5/16" x 2 1/2" lag bolts in place of toggle bolts on the side of the bracket aligned to the stud.

8420 Ceiling Mount

- For concrete install, use 6 x 5/16" x 1 5/8" female threaded anchors rated for 200 lbs each or greater pull and install the bracket using 6 x 1 1/2" grade 5 threaded bolts with flat washer.
- For plaster or drywall install, use 6 x 5/16" toggle bolts and washers rated for 60 lbs each or greater. The bolts with a washer should be fed through the bracket prior to attaching toggles. If a wood joist is available and the position is known, use 5/16" x 2 1/2" lag bolts in place of toggle bolts on the side of the bracket aligned to the joist.
- For acoustic tile, cut and lay 3/4" plywood equal in size dimension to the tile and install the bracket using 6 x 5/16" x 2 1/2" lag bolt with a washer.

2.3 Making Your First Configuration

Enabling a clock:

1. Navigate to *Display* → *Slides* to create a screen display.

2. Enter a Name and select Digital Clock. Customize your clock preferences. Press **Save**.
3. Go to *Display* → *Screens* to apply a screen display.
4. Under Default Screen, select the name of the display created in the previous step from the Slides dropdown menu.
5. Press **Save** at the bottom right of the page.

2.4 Power Requirements

For optimal performance, Algo recommends using an 802.3bt Type 3 (PoE++) switch for the 8410 and 802.3bt Type 4 (PoE++) switch for the 8420. The minimum power required for the 8410 is 802.3at (PoE+) power and the minimum power required for the 8420 is 802.3bt Type 3 power. If optimal switches are not available, a power injector may be used. If using a power injector that does not automatically negotiate its power capabilities, go to Advanced Settings → Admin to manually configure Automatic Power Detection versus Forced PoE++ mode. off.

2.5 Reset

A recessed reset button (RST) is located at the bottom of the device below the speaker and can only be used to reset the 8410 IP Display Speaker and 8420 IP Dual-Sided Display Speaker at time of power up. To return all the settings to the factory default for the 8410, reboot or power cycle the 8410/8420. Wait until the SIP LED flashes and then press and hold the reset button until the single blue LED on the bottom of the device begins a double flash pattern. Release the reset button and allow the unit to complete its boot process.



Important

Do not press the reset button until the blue SIP LED begins flashing.

A reset will set all configuration options to factory default including the login password.

Once booting has completed, pressing the reset button will cause the device to speak its IP address over the speakers.

3 APPLICATIONS

3.1 Voice Paging

The 8410 IP Display Speaker and 8420 IP Dual-Sided Display Speaker can be used for direct paging in addition to multicast. This allows direct communication with a single location.

3.2 Notification

The 8410 and 8420 provide effective notification alerting for emergency (e.g., lockdown, evacuation, reverse evacuation), safety (e.g., medical, workplace accident), and security (e.g., OSHA or similar workplace regulations) events.

For emergency alerting, the LCD screen, speaker, and LED flashers can be used together for a highly visible, attention-grabbing communication.

3.3 Visual Communication

When not used to display an active alert, the LCD screen can be configured to display a chosen image or layout for when in idle mode. This screen display can be a digital or analog clock synchronized to NTP, or an uploaded image. It can also display a series of selected images in a slideshow.

3.4 Multicast Receiver

The 8410 and 8420 are ideal for use as multicast receivers. Each alert can be mapped to multicast zones which can be associated with a display on the LCD screens to complement the audio announcements.

3.5 Scheduling

The 8410 IP Display Speaker can be paired with the 8301 IP Paging Adapter (sold separately) for scheduling tones and bells for schools, automated announcements for retail and healthcare, and workplace shift changes and breaks in warehouses.

3.6 InformaCast Compatible

The Algo 8410 IP Display Speaker is fully compliant with Singlewire InformaCast for telephone, security, and emergency alerting. The 8410 can display scrolling text and audible notifications for safety and security communication.

4 FEATURES

4.1 Setting Up Visual Display Content

The display on the 8410 is completely customizable. To set up the display screen:

1. Go to *Basic Settings* → *Screen*.
2. Under **Default** Screen, choose the following screen settings:
 - a. Number of Images
 - b. Images
 - c. Text Behavior
 - d. Text
 - e. Text Font
 - f. Text Position
 - g. Text Color
 - h. Text Size
 - i. Strobe Flash Pattern

To set the idle screen:

1. Go to *Basic Settings* → *Features*.
2. Under the **Screen** heading, select an Idle Pattern and choose the Screen Brightness.

4.2 SIP Paging: One 8410

The 8410 IP Display Speaker can be registered as a third-party SIP extension with a hosted or enterprise Communications Server supporting 3rd-party SIP endpoints.

To register the 8410 with the SIP server, use the *Basic Settings* → *SIP* tab in the web interface to enter the Communication Server IP address, extension, username, and password. This information will be available from the IT Administrator.

If VLAN is used, navigate to the *Advanced Settings* → *Network* tab to set VLAN options.



Important

Once the 8410 IP Display Speaker is using a VLAN, you will need to be on the same VLAN to access the web interface.

The Display Speaker may now be accessed by dialing its assigned extension from a telephone, device, or client. The adapter will auto-answer, play the default pre-announce tone, and allow voice paging until disconnected.

There are several configurable adapter options, such as:

- Increase or Decrease Speaker Volume
- Enable AGC (automatic gain control)
- Enable Ambient Noise Monitoring (speaker volume adapts to background noise)
- Enable Talkback
- Customize pre-announce tone file

The best voice paging quality and intelligibility will be obtained using the G.722 wideband audio codec. Most current IP telephones support G.722 which is sometimes referred to as “HD” voice or audio.

4.3 Multicast Overview

The 8410 IP Display Speaker is a multicast receiver and is able to receive IP audio multicast messages over the network to support larger deployment for both paging and notification. This provides a scalable and efficient method of building large scale notification solutions.

An Algo 8301 IP Paging Adapter & Scheduler can be configured with a SIP Page Extension to multicast to the 8410 IP Display Speaker. When called from a phone, the SIP registered 8301 will auto-answer and play the page audio over the 8410/8420 speaker.

Simultaneously, the registered 8301 endpoint broadcasts the audio over the network using RTP multicast to any number/combination of Algo IP display speakers, speakers, visual alerters, and paging adapters as required.

Receiver endpoints require a PoE network connection but do not require registration to the communication server.

Multicasting can also be used to distribute loud ring or other alerting (e.g., safety, security, or emergency events) over multiple Algo endpoints (e.g., 8190, 8196, 8188, 8186, 8128, 8201, 8301, and 8373).

4.3.1 SIP Paging: Multiple 8410s (Using Multicast)

To use the multicast feature, set up an 8410 IP Display Speaker as the Multicast Transmitter.

The Sender device will page normally while simultaneously streaming audio to the Receiver speakers (such as the 8410/8420). The Receiver speakers do not require SIP extensions and do not need to register with the SIP Communication Server.

To enable multicast streaming from the 8301 IP Paging Adapter & Scheduler, go to the web interface of the device and navigate to the *Basic Settings* → *Multicast* tab. Choose multicast mode ‘Sender’ and zone ‘All Call’. The multicast addresses pre-populated in the table, under *Advanced Settings* → *Advanced Multicast*, will work in most cases and should only be altered for rare cases.

To enable multicast monitoring in the 8410 IP Display Speaker, go to the web interface for reach device and navigate to *Basic Settings* → *Multicast*. Choose multicast mode ‘Receiver’. There is no need to select a zone as the speaker will automatically monitor the ‘All Call’ zone IP address.

The page pre-announce tone is generated from the Sender. The following options are valid for each multicast Receiver:

- Increase or Decrease Speaker Volume
- Enable Ambient Noise Monitoring (speaker volume adapts to background noise)

4.3.2 SIP Paging: Multiple Display Speakers (Using Individual SIP extensions)

In some cases, it may be desirable for every speaker to have a SIP extension. Multicast may still be used to page multiple speakers, but each speaker can also be called individually or generate a call when appropriately configured.

A speaker configured as a SIP Multicast Slave will give its highest priority to the 'Priority Call' zone. Other than the 'Priority Call' zone, a page using its SIP extension, has priority over all other multicast zones.

Communication Servers with the capability of dialing many SIP extensions simultaneously for paging may be able to create zones by calling "page groups" and page telephone speakers in conjunction with overhead speakers.

4.4 SIP-Activated Visual Notification Alerts

In addition to audible notifications, the 8410/8420 can multicast visual alerting with the LED flashers. When a call is made to the SIP extension, the 8410/8420 will flash the selected light pattern. Often, the flashers for the 8410 will be part of a hunt group or ring group to flash in conjunction with an audio notification.

There are several configurable strobe options:

- Flash Pattern
- Brightness

4.5 Color TLS for SIP Signaling and Provisioning

Algo devices support Transport Layer Security (TLS). This feature adds security by ensuring that Algo products can trust the hosted SIP server. This is useful for when third-party devices or attackers may try to intercept, replicate, or alter Algo products, and try to connect to the server. TLS protocol will ensure that third parties cannot read/modify any actual data. Previously security was less of a concern because phone systems were on isolated networks, but hosted services are becoming increasingly more common. Using a hosted SIP service requires traffic to be sent over the public internet and thus much more susceptible to attacks. Signed certificates are an important piece in the Algo device's operation, to ensure the security, integrity, and privacy of its communication. Algo components that use TLS are **Provisioning** and **SIP Signaling**.

These Algo devices each come pre-loaded with certificates from a list of trusted certificate authorities (CA), which are installed in the hardware at the time of manufacture. Note these pre-installed trusted certificates are not visible to users and are separate from the 'certs' folder.

The TLS handshake happens to make sure that the client and server can trust each other, and once that trust is established, the two parties can freely send encrypted data and decrypt any data that they receive. After the TLS handshake process is complete, a TLS session is established, and the server and client can then exchange messages that are symmetrically encrypted with shared (pre-Sender) secret key.

For further details, reference Algo's guide for [Securing Algo IP Endpoints: TLS and Mutual Authentication](#).

Uploading Public CA Certificates to Algo SIP Endpoints

To install the public CA certificate on the 8410/8420, follow the steps below:

3. Obtain a public certificate from your Certificate Authority.
4. Rename the public certificate 'siptrusted.pem' (only .pem format is supported).
5. In the web interface of the Algo device, navigate to the *Advanced Settings* → *File Manager*.
6. Upload the certificate files into the 'certs' directory. Click the Upload button in the top left corner of the file manager and browse to the certificate.

For **SIP** TLS, no default public CA certificates are used; only the above .pem file is supported, so this certificate file must be uploaded in order for SIP TLS authentication to occur.

For **Provisioning** TLS, only the default pre-installed public CA certificates are supported; No .pem file can be uploaded in this case.

HTTPS Provisioning

Provisioning can be secured by setting the 'Download Method' to 'HTTPS' (under the *Advanced Settings* → *Provisioning*). This prevents configuration files from being read by an unwanted third-party. This resolves the potential risk of having sensitive data stolen, such as admin passwords and SIP credentials.

Status
Basic Settings
Display
Additional Features
Advanced Settings
System
Logout

Network
Admin
Users
Time
Provisioning
Advanced Audio
Advanced SIP
Advanced Multicast

Provisioning Settings

Mode

Provisioning Mode Enabled Disabled

Settings

Server Method Auto (DHCP Option 66/160/150)
 DHCP Option 66 only
 DHCP Option 160 only
 DHCP Option 150 only
 Static
Auto mode automatically checks all 3 DHCP options for an active provisioning server, in the order listed.

Static Server

Download Method TFTP FTP HTTP HTTPS

Validate Server Certificate Enabled Disabled
Validate the server against common certificate authorities. To validate against additional certificates, use the "System > File Manager" tab to upload a Base64 encoded X.509 certificate file in .pem, .cer, or .crt format to the 'certs/trusted' folder.

Auth User Name

Auth Password

Config Download Path

Firmware Download Path

Partial Provisioning Enabled Disabled
Allow support for "-i" incremental provisioning files. Disable for enhanced security if not using this feature.

Check-sync Behavior Always Reboot Conditional Reboot
If 'Conditional Reboot' is selected, the device will check with the provisioning server and only reboot if new config is found (unless 'reboot=true' is provided as a parameter in the check-sync event).

Sync Start Time
Schedule a time (HH:mm:ss) for the device to perform a sync according to the 'Check-sync Behavior' option above. Leave blank to disable the feature.

Sync End Time
If set, the device will sync at a random time in the window between Start Time and End Time. Setting an End Time earlier than Start Time indicates an overnight period. Leave blank to sync at Start Time exactly.

Sync Frequency Daily Selected Days Only

Zero Touch Provisioning
ZTP is disabled and can only be re-enabled with a factory reset.



Important

To verify the server, enable the 'Validate Server Certificate' option. This then checks if the certificate that is provided by the server is signed by any of the CAs included in the list of trusted CAs (used by the Debian infrastructure and Mozilla browsers). If we receive a certificate signed by any of these CAs, then that server will be trusted.

The 'Validate Server Certificate' parameter can also be enabled through provisioning:

```
prov.download.cert = 1
```

Encrypting SIP and RTP Communication

SIP signalling is secured by setting 'SIP Transportation' to 'TLS' (under the *Advanced Settings* → *Advanced SIP* tab). Setting it to 'TLS' ensures that the SIP traffic will be encrypted. The SIP signalling is responsible for establishing the call (the control signals to start and end the call with the other party), but it does not contain the audio.

For the audio (voice) path, use the setting '**SDP SRTP Offer**'. Setting this to '**Optional**', means the SIP call's RTP audio data will be encrypted (using SRTP) if the other party also supports audio encryption. If the other party does not support SRTP, then the call will still proceed, but with unencrypted audio. To make audio encryption mandatory for all calls, set '**SDP SRTP Offer**' to '**Standard**'. In this case, if the other party does not support audio encryption, then the call attempt will be rejected.

Status
Basic Settings
Additional Features
Scheduler
Advanced Settings
System
Logout

Network
Admin
Users
Time
Provisioning
File Manager
Advanced SIP
Advanced Multicast

Advanced SIP Settings

General

SIP Transportation

 ⓘ Select Auto to check DNS NAPTR record, then try UDP/TCP.
 ⓘ In TLS mode, if the SIP Server requires endpoints to be authenticated, a PEM file containing both a device certificate and a private key needs to be installed on the Algo device. Use the "Advanced Settings > [File Manager](#)" tab to upload a certificate file renamed to 'sipclient.pem' in the 'certs' folder.
 ⓘ To force the Algo device to authenticate the SIP server, a certificate obtained from the SIP server needs to be installed. Use the "Advanced Settings > [File Manager](#)" tab to upload a certificate file renamed to 'siptrusted.pem' in the 'certs' folder.

SIPS Scheme
 Enabled Disabled

SDP SRTP Offer

SIP Outbound Support (RFC 5626)
 Enabled Disabled

 ⓘ Enable this option to support best networking practices according to RFC 5626. This option should generally be enabled if the Algo device is being registered with a hosted server or if TLS is being used for SIP Transportation.

Outbound Proxy

Register Period (seconds)

NAT

Media NAT
 None ICE STUN

Server Redundancy

Server Redundancy Feature (Multiple SIP Server Support)
 Enabled Disabled

Interoperability

Keep-Alive Method
 None Double CRLF

 ⓘ This setting will enable sending periodic CRLF messages for both UDP and TCP connections.

Use Outgoing TLS port in SIP headers
 Enabled Disabled

 ⓘ Use ephemeral port number from outgoing SIP TLS connection instead of listening port number in SIP Contact and Via headers. This is useful to connect the device to some local SIP servers, like Asterisk or FreeSWITCH.

Do Not Reuse Authorization Headers
 Enabled Disabled

 ⓘ When enabled, all SIP authorization information from the last successful request will not be reused in the next request.



Important

For a SIP server to validate the Algo device, an additional certificate has to be manually installed on the 8410/8420. To add this user certificate file use a '.pem' filetype extension and have the file named 'sipclient'. This is done by manually adding a file named 'sipclient.pem', which contains a device certificate and private key, to the 'certs' folder (under the 'Advanced Settings' tab File Manager). In the future, '.crt', '.cer', and '.der' certificate extensions will also be supported and you will not be restricted to naming the file 'sipclient.pem'.

5 WEB INTERFACE

5.1 Stats

5.1.1 Device Status

Web Interface Login

Welcome to the Algo 8410 IP Display Speaker

Setting up your IP Display Speaker:

Step 1: Configure your IP Display Speaker
Log in with the default password and use the Basic Settings pages to set up the basic information.

Step 2: Check network settings (Optional)
Use the Network page under the Advanced Settings tab to change network settings. The default setting for the device is to obtain its IP address from a DHCP server. Contact your Network System administrator if you plan to assign a static IP address, Mask, and Gateway to the device.

Step 3: Secure your IP Display Speaker (Optional)
Use the Admin page under the Advanced Settings tab to change the administrator password.
⚠️ Changing the password is extremely important if the device is directly connected to a public network.

Step 4: Register your IP Display Speaker (Optional)
Please register your product using the link below:
<http://www.algosolutions.com/register>
Registration ensures your access to the latest upgrades to this product and important service notices.

Login

Password (default: **algo**)

Status

Device Name	displayspk-18000f	
SIP Registration	Page	No Account
Call Status	Idle	
Proxy Status	Single proxy mode	
Provisioning Status	None Found	
MAC	00:22:ee:18:00:0f	
IPv4	10.30.250.48/8, Gateway: 10.0.1.1	
Date / Time	Thu Feb 9 16:36:12 GMT 2023	
Multicast Mode	Disabled	
Volume	Page Volume: 4 (-18dB)	
PoE Detection	PoE++ 802.3bt Type 3 (Max 51W)	
Power Consumption	Current: 36 (of 255), Voltage: 248 (of 255)	
Ambient Light Level	5 (of 1024)	
Relay Input Status	Disabled	

Figure 1: 8410 Status

The web interface requires a password to login to see the device settings. The default password is 'algo'. This password can be changed in the **Admin** tab after logging in the first time.

**Note**

Web Interface is accessed by entering 8410/8420 IP Address into the web browser.

**Important**

It is highly recommended to change the default password if the device is directly connected to a public network.

Status

The Status page of the device will be available before and after logging on. This section can be used to check the status of the 8410 for the following:

- SIP Registration
- Call Status
- Proxy Status
- Provisioning Status
- MAC
- IPv4
- Date/Time
- Multicast Mode
- Volume
- PoE Detection
- Relay Input Status

**Note**

For security purposes, the Status page can be hidden when logged out through the settings under the **Advanced Settings > Admin** tab.

These options may change depending on how the device is configured.

5.2 Basic Settings

5.2.1 SIP

The *SIP* tab allows for the SIP server information and account credentials to be entered. This information can be obtained from your telephone system administrator or hosted account provider. After entering the information and saving the settings, go to the *Status* tab to confirm the registration was successful.

SIP Settings

SIP

i This section allows the SIP server information & account credentials to be entered. This information should be obtained from your telephone system administrator or hosted account provider. After saving these settings, see the [Status](#) tab to confirm successful registration.

SIP Domain (Proxy Server) *i*
i Default port is 5060. To specify a different port, enter PROXY:PORT, e.g. my_proxy.com:5070, or 192.168.1.10:5080.

Ring/Alert Mode Monitor "Ring" event on registered SIP extension
 None

Ring Extension

Authentication ID

Authentication Password *i* *h*

Display Name (Optional)

i The device will detect inbound ring events on this extension and play the alerting tone (and multicast if configured) until the inbound call stops ringing. It will not answer the call on this extension.

Page Extension

Authentication ID

Authentication Password *i* *h*

Display Name (Optional)

i The device will auto-answer any inbound call received on this extension and provide a voice paging path (and multicast if configured).

Save

Figure 2: 8410 Basic Settings → SIP



Important

Anytime changes are made to settings in the web interface the **'Save'** button must be clicked to save the changes.

SIP Domain (Proxy Server)

The IP address (e.g., 192.168.1.111) or domain name (e.g., myserver.com) of the SIP Server.

Ring / Alert Mode

This is the option for adding a second SIP extension for a Ring event. If activated ("Monitor" is selected), the screen expands to show blocks for SIP extension parameters for a Ring/Alert Extension to be entered.

The device will detect inbound ring events on this extension and play the alerting tone (and multicast if configured) until the inbound call stops ringing. It will not answer the call on this extension.

Ring Extension

This is the SIP extension for the Ring parameter of the 8410.

Page Extension

This is the SIP extension for the Page parameter of the 8410. The device will auto-answer any inbound call received on this extension and provide a voice paging path (and multicast if configured).

Authentication ID

Also referred to as 'Username' for some SIP servers. This, in some cases, may be the same as the Ring and/or Page extension. The authentication is a name you choose to represent the page extension.

Authentication Password

This is the SIP password provided by the system administrator for the registered SIP account. Up to eight (8) characters can be implemented. The password can be used to authenticate SIP users.

Display Name

The Display Name is shown on a receiving phone to which a SIP call is made. For the display name to be shown, the PBX and phone(s) need to be configured to display this message as the Caller ID.

5.2.2 Features

Status	Basic Settings	Display	Additional Features	Advanced Settings	System	Logout
SIP	Features	Multicast				
Features						
Inbound Ring Settings						
<p><i>i</i> These settings apply to events triggered by the Ring Extension(s) & Emergency Alerts sections. The Play/Loop/Stop buttons can also be used to test the device and set the appropriate volume level.</p>						
Ring/Alert Tone	warble2-med.wav	▼	Play	Loop	Stop	
Ring/Alert Screen Pattern	<None>	▼				
Ring/Alert Volume	4	▼	Apply			
Ring Limit	No limit	▼	<i>i</i> 1 ring = 6 seconds.			
Inbound Page Settings						
Page Speaker Volume	4	▼	Apply	<i>i</i> When in Receiver mode, note that this is the default volume control for all audio received via multicast.		
Page Mode	<input type="radio"/> One-way <input type="radio"/> Two-way <input checked="" type="radio"/> Delayed <i>i</i> "Delayed" mode stores the page audio temporarily, and then broadcasts it after the call is hung-up. This can help avoid feedback. Note: The Opus transmitter codec is not supported with Two-way paging.					
Delayed Page	<input checked="" type="radio"/> Play once <input type="radio"/> Play twice					
Page Timeout	5 minutes	▼	<i>i</i> Maximum page timeout in Delayed mode is 5 minutes.			
Page Tone	<Default>	▼	<i>i</i> Use only Default, or custom uploaded file. The other pre-installed tone files all contain silence at the end in order to generate ring "cadence" of 6 seconds. This silence will block the voice path for several seconds at the start of a page.			
Page Screen Pattern	<None>	▼				
G.722 Support	<input checked="" type="radio"/> Enabled <input type="radio"/> Disabled <i>i</i> Applies to codec used during SIP negotiation only. Multicast codec is configured separately.					
Passcode Protected Page Extensions	<input checked="" type="radio"/> Enabled <input type="radio"/> Disabled <i>i</i> Set all page extensions to require the caller to enter a passcode. Setting a passcode helps prevent unintentional pages. When prompted, the caller must enter the passcode followed by the # sign before the page can be accepted. The passcode prompt will be played before any other action.					
Apply To All Page Extensions	<input checked="" type="radio"/> Enabled <input type="radio"/> Disabled					
Passcode	<input type="text"/> <i>i</i> Maximum length = 15 digits					
Passcode Prompt Tone	<Default>	▼				
DTMF Detection Type	<input checked="" type="radio"/> Auto <input type="radio"/> RTP Telephony Event (RFC 4733) <input type="radio"/> RTP In-band <input type="radio"/> SIP INFO					
Audio Processing						
Ambient Noise Compensation	<input checked="" type="radio"/> Enabled <input type="radio"/> Disabled <i>i</i> Automatically adjust speaker level in response to ambient noise level detected at the device prior to start of each call.					
Ambient Noise Compensation No Loss	<input checked="" type="radio"/> Enabled <input type="radio"/> Disabled <i>i</i> Configure the Ambient Noise Compensation algorithm to only use levels at or above the current volume.					
Ambient Noise Compensation Max Volume	10	▼	<i>i</i> Set maximum speaker level in response to ambient noise.			
Automatic Gain Control (AGC)	<input checked="" type="radio"/> Enabled <input type="radio"/> Disabled <i>i</i> Automatically maximize level of voice received from calling phone in order to make page volume more consistent.					
Screen						
Idle Pattern	<Use Default Screen Pattern>	▼				
Screen Brightness	5	▼	Apply			
<input checked="" type="checkbox"/> Save						

Figure 3: 8410 Basic Settings → Features

Inbound Ring Settings

Ring settings apply to events triggered by Ring Extensions and Emergency Alerts.

Ring/Alert Tone

Select an audio file to play when a ring event is detected on the SIP Ring Extension. The audio file may be played immediately to an associated speaker from the web interface for test purposes using the Play, Loop, and Stop buttons. During multicast, the device will broadcast an audio stream using the Sender's selected ring tone.



Note

This is the "Default" tone that will be played if selected for Multicast, Additional Ring Extension settings.

Ring/Alert Screen Pattern

Select a screen pattern to display on the LCD screen on inbound ring events. Screen patterns are configured under *Display → Screens*.

Ring/Alert Volume

Set the speaker volume for a SIP Ring event. This setting is an amplifier gain control, and the output level will depend on the levels recorded into the source audio file played from memory. This setting is only used for local tones, and not when receiving multicast (see Page Speaker Volume below).

Ring Limit

Typically set to no limit, this feature can be used to set a limit on how long the speaker will ring before timing out. A new ring event is required before the speaker will play the audio file again.

Inbound Page Settings

Page Speaker Volume

This is the Page Speaker Volume control for SIP or multicast paging. This is an amplifier gain control and the output level will depend on streaming level. This setting will apply to all inbound multicast streams (for Receiver mode only), regardless of content.

Page Mode

A call to the SIP page extension can be one-way, two-way (using an external microphone), or delayed. In delay mode, the speaker will store the page into memory and then play after disconnecting.

Delayed Page

Delayed Page allows for a user to record a message before it is played over the speakers. To cancel a page while in delay mode, press "*" to while the recording state is in process to prevent it from being sent after hanging up.

Page Timeout

Page Timeout is the maximum duration for a page. The call will be terminated when the timeout occurs whether anyone is speaking or not. This is useful for situations when someone accidentally forgets to hang up, preventing the paging system from getting stuck in the active state. A time limit may be set for an active page.

Page Tone

Select a pre-announce tone for paging. This tone will play to announce a Page is starting. Use only the Default or custom uploaded files. Other pre-installed tone files contain silence at the end to generate ring "cadence" of 6 seconds. This silence will block the voice path for several seconds at the start of a page. The "Default" tone will play the page-notif.wav file.



Note

The "Default Page Tone", in Advanced Multicast, will play the tone set here.

Page Screen Pattern

Select a screen pattern to display on the LCD screen on inbound page events. Screen patterns are configured under *Display* → *Screens*.

G.722 Support

G.722 enables wideband audio for optimum speech intelligibility. Enable or disable the G.722 codec.

Passcode Protected Page Extensions

When enabled, the caller must enter the passcode followed by the # sign before the page can be accepted. Setting a passcode helps prevent unintentional pages. Passcodes can be up to 15 digits and must be numbers only.

Apply to All Page Extensions

Choose to apply a passcode to all page extensions.

Passcode

Only visible when 'Passcode Protected Page Extensions' is set to 'Enabled'. Enter the desired numerical passcode (maximum length of 15 digits).

Passcode Prompt Tone

Only visible when 'Passcode Protected Page Extensions' is set to 'Enabled'. Select the tone to be played to notify the user to enter the passcode before paging.

DTMF Detection Type

Select the preferred dual-tone multi-frequency (DTMF) detection method. DTMF is a technology used with touch tone phones, best known to users as the sound made when pressing a number key. In the 8410 or 8420, this is used for multi-zone selection, passcode, etc.

Audio Processing

Ambient Noise Compensation

Ambient Noise compensation will allow the speaker level to adjust automatically in response to ambient noise levels detected at the device prior to the start of each call.

Ambient Noise Compensation No Loss

Configure the Ambient Noise Compensation algorithm to only use levels at or above the current volume. The current volume is the minimum speaker volume when this setting is enabled.

Ambient Noise Compensation Max Volume

Based on ambient noise levels, a maximum volume can be set for the speaker.

Automatic Gain Control (AGC)

AGC normalizes the audio level. This ensures the audio level heard near the speaker is always at a consistent level, independent of the phone that is used to answer the call.

Screen

Idle Pattern

Select a pattern to be displayed on the screen for when the 8410 or 8420 is idle. Patterns can include up to several screen displays and can vary to include a single image, a notification template, a clock display, and other configurations.

Screen Brightness

The screen brightness level can be adjusted according to the placement of the screen within a building to optimize visibility of content. Select a brightness level for the display screen on the 8410 or 8420.

5.2.3 Multicast

Multicast IP Addresses

Each 8410 or 8420 has its own IP address and shares a common multicast IP and port number (multicast zone) for multicast packets. The Sender transmits to a configurable multicast zone, and the Receiver units listen to all the multicast zones assigned to them.

The network switches and router see the packet and deliver it to all the members of the group. The multicast IP and port number must be the same on all the Transmitter and Receiver units of one group. The user may define multiple zones by picking different multicast IP addresses and/or port numbers.

1. Multicast IP addresses range: 224.0.0.0/4 (from 224.0.0.0 to 239.255.255.255)
2. Port numbers range: 1 to 65535
3. By default, the 8410 or 8420 is set to use the multicast IP address 224.0.2.60 and the port numbers 50000-50008

Make sure that the multicast IP address and port number do not conflict with other services and devices on the same network.

Multicast Page Zones

The 8410 or 8420 supports nine 'basic' multicast zones. These zones are defined by the multicast IP addresses.

Somewhat arbitrarily, these zones are defined below but may be used in other ways. The important consideration is that there is a priority hierarchy – streaming activity on a zone higher on the list, will be treated as a higher priority than a zone lower down on the list – with music being the lowest priority.

1. Priority
2. All Call
3. Zone 1
4. Zone 2
5. Zone 3
6. Zone 4
7. Zone 5
8. Zone 6
9. Music

“Expanded” zones can also be enabled, in *Basic Settings* → *Multicast*, allowing up to 50 zones in total. These have the same behaviors as the basic zones but are hidden by default to simplify the interface.

5.3 Multicast (Transmitter/Sender Settings)

The screenshot displays the 'Multicast Settings' configuration page. At the top, there are navigation tabs: Status, Basic Settings, Display, Additional Features, Advanced Settings, System, and Logout. Below these, there are sub-tabs for SIP, Features, and Multicast. The main content area is titled 'Multicast Settings' and is divided into several sections:

- Multicast Mode:** Includes radio buttons for 'None', 'Transmitter (Sender)' (selected), and 'Receiver (Listener)'. A note states: 'Multicast Zone Definitions can be found in "Advanced Settings > Advanced Multicast".'
- Multicast Type:** Includes radio buttons for 'Regular (RTP)' (selected), 'Polycom Group Page', 'Polycom Push-to-Talk', 'Regular RTP + Polycom Group Page', and 'Regular RTP + Polycom Push-to-Talk'. A note states: 'Regular mode uses RTP audio packets compatible with all Algo SIP endpoints, and most multicast-enabled phones.'
- Number of Zones:** Includes radio buttons for 'Basic Zones Only' (selected) and 'Basic and Expanded Zones'.
- Transmitter (Sender) Zone Settings:**
 - Zone Selection Mode:** Includes radio buttons for 'DTMF Selectable Zone' (selected) and 'Single Zone'. A note states: 'For additional capabilities allowing unique SIP extensions per zone, see "Additional Features > More Page Extensions".'
 - Transmitter Single Zone:** A dropdown menu is set to 'Zone 1'. A note states: 'If "DTMF Selectable Zone" is selected above, then this single zone setting will not apply to Paging (since the zone can now be dynamically selected per call using DTMF), but it will still apply to the Ring Extension and Relay triggered events.'
 - Speaker Playback Zones:** Includes checkboxes for 'Priority Call', 'All Call', 'Music', 'Zone 1', 'Zone 2', 'Zone 3', 'Zone 4', 'Zone 5', and 'Zone 6', all of which are checked. A note states: 'Allows Multicast Transmitter device to play audio for selected zones only. This is useful if using DTMF Selectable Zone mode (or More Page Extensions per zone) and wishing to make the Transmitter a member of only certain zones.'
- DTMF Settings:**
 - Zone Selection Tone:** A dropdown menu is set to '<Default>'.
 - Two Digit Selection:** Includes radio buttons for 'Enabled' and 'Disabled' (selected). A note states: 'If enabled, all DTMF Selectable Zones will require two digits. As a result, Basic Zones must be prefixed with "0" (ie. 01, 02, etc) and Expanded Zones no longer need to be prefixed with "**'.'

A 'Save' button is located at the bottom right of the settings area.

Figure 4: Multicast transmitter mode settings



Note

See (Advanced Settings > Advanced Multicast) section for more information on populated IP values.

Multicast Mode

Multicast Mode (Transmitter/Sender Selected)

If Transmitter mode is enabled the 8410 or 8420 will broadcast an IP stream when activated in addition to playing the audio. (Note that the 8410 or 8420 cannot be both a multicast Transmitter and Receiver simultaneously).

Multicast Type

The 8410 or 8420 may broadcast multicast paging, compatible with Polycom “on premise group paging” protocol and most multicast-enabled phones that use RTP audio packets.

Select 'Regular' if solely multicasting to Algo SIP endpoints and/or multicast-enabled phones.

To multicast page announcements solely to Polycom phones, select 'Polycom Group Page' or 'Push-to-Talk'. Then, configure the 8410 or 8420 with the 'Polycom Zone' (IP Address and Port) and 'Polycom Default Channel'.

**Note**

Always ensure that the multicast settings on all Receiver devices match those of the Transmitter

Select 'Regular RTP + Polycom Group Page/Push-to-Talk' to multicast page audio to both Polycom phones, Algo SIP endpoints, and multicast-enabled phones.

Number of Zones

Select 'Basic Zones Only' if configuring nine or fewer multicast zones (shown beside 'Speaker Playback Zones') or select 'Basic and Expanded Zones' to configure up to 50 zones. The expanded zones have the same behavior as the basic Receiver zones but are hidden by default to simplify the interface.

Transmitter (Sender) Zone Settings

Polycom Group Selection Mode

'Single Zone' always broadcasts on one pre-configured Polycom Group. In 'DTMF Selectable Zone' mode, the group is determined by the DTMF selection between 1 – 50.

Zone Selection Mode

"Single Zone" mode always broadcasts on one IP address.

**Note**

Multiple SIP extensions can be registered on the Transmitter device. Each extension is mapped to a unique zone, allowing zones to be called directly (e.g., from speed-dial keys). See Additional Features → More Page Extensions.

'DTMF Selectable Zone' mode, offers dynamic zone selection and requires only the Transmitter device to have a registered SIP Extension. The zone definitions can be found in the *Advanced Settings* → *Advanced Multicast* tab.

In 'DTMF Selectable Mode', to page, dial the SIP extension of the Transmitter device: #####, then dial the desired DTMF page zone (e.g., 1, 2, etc.) on the keypad when prompted.

1. Press DTMF Extension 9 for Priority Call
2. Press DTMF Extension 0 (or 8) for All Call
3. Press DTMF Extension 1 for Zone 1
4. Press DTMF Extension *10 for Zone 10
5. Press DTMF Extension *11 for Zone 11

**Note**

DTMF codes for zones 10 and higher start with an ""*
All DTMF codes and respective zones are available in Advanced Settings → Advanced Multicast.

Zone Selection Tone

Only visible when “Zone Selection Mode” is set to ‘DTMF Selectable Zone’. The tone played over the phone to prompt the user to select a zone to multicast to.

Transmitter Single Zone

The zone that multicast stream will be sent to by default. If ‘DTMF Selectable Zone’ is chosen above, this setting will not apply to Paging, since the zone now must be dynamically selected per call via DTMF. However, the specified Transmitter ‘Single Zone’ setting is still used for any multicast events triggered by the Ring, analog input, or the relay input.



Note

The Transmitter Single Zone is the default zone used for any multicast actions unless an option is created for a custom zone with specific parameters.

Speaker Playback Zones

The Speaker Playback Zones allows the Transmitter device to play audio for selected zones only. This is useful if using the DTMF Selectable Zone mode (or More Page Extensions per zone) with the intention of making the Transmitter unit a member of only certain zones. In this case, the Transmitter does not participate in the Zone, but it transmits certain traffic.

Expanded Speaker Playback Zones

Up to 50 zones can be shown and are only visible when ‘Basic and Expanded Zones’ is selected.

DTMF Settings

Zone Selection Tone

This is the prompt to select a zone. This may be used as an interactive voice response (IVR) menu by uploading a custom audio file through *System* → *File Manager* in the Tones folder. Each zone may use a different tone. This can be configured in *Advanced Settings* → *Advanced Multicast*.

Two Digit Selection

When enabled, all DTMF Selectable Zones will require two digits. As a result, Basic Zones must be prefixed with ‘0’ and Expanded Zones will no longer need to be prefixed with ‘*’.

5.4 Multicast (Receiver Settings)

The screenshot displays the 'Multicast Settings' configuration page. At the top, there are navigation tabs: Status, Basic Settings, Display, Additional Features, Advanced Settings, System, and Logout. Below these, there are sub-tabs: SIP, Features, and Multicast. The main content area is titled 'Multicast Settings' and is divided into several sections:

- Multicast Mode:** Includes radio buttons for 'None', 'Transmitter (Sender)', and 'Receiver (Listener)'. A note states: 'Multicast Zone Definitions can be found in "Advanced Settings > Advanced Multicast".'
- Multicast Type:** Includes radio buttons for 'Regular (RTP)', 'Polycom Group Page', and 'Polycom Push-to-Talk'. A note states: 'Regular mode uses RTP audio packets compatible with all Algo SIP endpoints, and most multicast-enabled phones.'
- Number of Zones:** Includes radio buttons for 'Basic Zones Only' and 'Basic and Expanded Zones'.
- Receiver (Listener) Zone Settings:**
 - Basic Receiver Zones:** Includes checkboxes for 'Priority Call', 'All Call', 'Music', 'Zone 1', 'Zone 2', 'Zone 3', 'Zone 4', 'Zone 5', and 'Zone 6'. A note states: 'A multicast to the Priority Call zone will override all other events on the device, except for a direct call to a Priority Page Extension in the More Page Extensions tab.'
 - Expanded Receiver Zones:** Includes checkboxes for 'Zone *10' through 'Zone *50'. Below these are 'Select All' and 'Clear All' buttons.

A 'Save' button with a green checkmark is located at the bottom right of the settings area.

Figure 5: Multicast receiver mode settings

Multicast Mode

Multicast Mode (Receiver Selected)

If Receiver mode is enabled the 8410 or 8420 will activate when receiving a multicast message. It will mimic the audio stream but use local volume settings ('Page Speaker Volume' in *Basic Settings* → *Features*).

Multicast Type - Regular

Select "Regular" if receiving multicast from other Algo SIP endpoint(s) and/or multicast-enabled phone(s) that use RTP audio packets.

Number of Zones

Select 'basic' zones if configuring nine or fewer multicast zones or 'expanded' to configure up to 50 zones. The expanded zones have the same behaviour as the basic Receiver zones but are hidden by default to simplify the interface.

Multicast Type – Polycom Group Paging/Push-to-Talk

The 8410 or 8420 may receive multicast paging compatible with Polycom “*on premise group paging*” protocol.

To configure the 8410 or 8420 as a Receiver to play Polycom page announcements, select ‘Group Page’ or ‘Push-to-Talk’. Then enter the Polycom Zone (IP Address and Port) that matches the configuration of the Polycom phones and Channels. The ‘Default Channel’ is the target group in a Polycom paging environment.

The screenshot shows the 'Multicast Settings' configuration page. At the top, there are navigation tabs: Status, Basic Settings, Additional Features, Scheduler, Advanced Settings, System, and Logout. Below these, there are sub-tabs: SIP, Features, and Multicast. The main content area is titled 'Multicast Settings' and contains three sections:

- Multicast Mode:** Includes radio buttons for 'None', 'Transmitter (Sender)', and 'Receiver (Listener)'. The 'Receiver (Listener)' option is selected. A note below states: "Multicast Zone Definitions can be found in 'Advanced Settings > Advanced Multicast'".
- Multicast Type:** Includes radio buttons for 'Regular (RTP)', 'Polycom Group Page', and 'Polycom Push-to-Talk'. The 'Polycom Group Page' option is selected. A note below states: "Regular mode uses RTP audio packets compatible with all Algo SIP endpoints, and most multicast-enabled phones."
- Polycom Group Paging/Push-to-Talk:** Includes a text field for 'Polycom Zone' containing '224.0.1.116:5001'. A note below states: "Enter the same Multicast IP Address & Port number as configured on the Polycom phones." Below this is a grid of checkboxes for 'Polycom Receiver Channels' from Group 1 to Group 25. Groups 1, 24, and 25 are checked. There are 'Select All' and 'Clear All' buttons. A note below states: "A multicast to Groups 24 or 25 will override all other events on the device, except for a direct call to a Priority Page Extension in the More Page Extensions tab."

A 'Save' button with a green checkmark is located at the bottom right of the configuration area.

The Polycom phone used as page audio source for the 8410 or 8420 must be configured to use either the G.711 or G.722 audio codec. **The Polycom phone(s) must also be configured with the “Compatibility” setting (“ptt.compatibilityMode”) disabled** in order for this codec setting to be applied.

If using a Polycom phone as the Multicast Transmitter, a tone may be set for any of the 25 Polycom Groups configured on the Algo device. If an Algo device is used as a Multicast Transmitter, a tone does not have to be set as the Algo Transmitter will provide its own tone. Polycom Group Tones can be set in *Advanced Settings* → *Advanced Multicast*.

Receiver (Listener) Zone Settings

Basic Receiver Zones

Select one or more multicast zones for the 8410 or 8420 to subscribe to.



Note

Multicast zone priority is based on the zone definition list order (from top to bottom) in *Advanced Settings* → *Advanced Multicast*.

Expanded Receiver Zones

Up to 50 zones can be shown, however, they are only visible when 'Basic and Expanded Zones' is selected.

5.5 Display

The 8410 and 8420 allow flexible visual communication via the display. The displays can be configured to deliver a variety of notification messages, such as clocks, scrolling texts, slideshow-style images, flashing announcements or general messages. The power of the device comes down to optimizing the screens for your application. In the next section, we will go through how to configure different slide options.

Within the Display tab, there are three (3) tab options: Screens, Slides, Data. The Screens tab allows you to select a slide to display on the device, the Slides tab allows you to create new or existing slides to use, the Data tab allows you to download images from the Algo server to use in the slides.

5.5.1 Screens

In this tab, you can dictate what will be displayed on the screen. Slides are created in the Slides tab. The Screens tab allows you to assign content to display. You can choose the screens to display to SIP or multicast events as well as the default display for when an event is not in progress.

Status	Basic Settings	Display	Additional Features	Advanced Settings	System	Logout
--------	----------------	----------------	---------------------	-------------------	--------	--------

Screens		Slides	Data
----------------	--	--------	------

Screen

Default Screen

Number of Slides	4	
Slides	Time and date background	School date and time
	Digital clock	Analog clock
Slide Duration (seconds)	5	
Strobe Flash Pattern	Off	
Test	Start Stop	

Screens

Name	Screen 1	
Number of Slides	1	
Slides	<None>	
Strobe Flash Pattern	Off	
Test	Start Stop	

Name	Screen 2	
Number of Slides	1	
Slides	<None>	
Strobe Flash Pattern	Off	
Test	Start Stop	

Name	Screen 9	
Number of Slides	1	
Slides	<None>	
Strobe Flash Pattern	Off	
Test	Start Stop	

Name	Screen 10	
Number of Slides	1	
Slides	<None>	
Strobe Flash Pattern	Off	
Test	Start Stop	

Default Screen

Number of Slides

Select the number of slides to cycle through on the display screen.

Slides

In order from left to right, top to bottom, select each slide to display. Slides can be created under *Display* → *Slides*.

Slide Duration (seconds)

Choose how long each slide will show on the display screen in seconds.

Strobe Flash Pattern

Choose a flash pattern for the LEDs. If enabled, this will be displayed while the default screen is on.

Strobe Brightness

When strobe flash pattern is selected, the option for the strobe brightness can be selected.

Strobe Color

Select a color to display.

Screens

Name

Choose a name that coordinates with the intention of your screen's usage.

Number of Slides

Select the number of slides you wish to display for the screen display.

Slides

In order from left to right, top to bottom, select each slide to display. Slides can be created under *Display* → *Slides*.

Strobe Flash Pattern

Choose a flash pattern for the LEDs. If enabled, this will be displayed while the default screen is on.

5.5.2 Slides

Slides can be created or edited in this tab based on event. Preconfigured templates are provided to customize content.

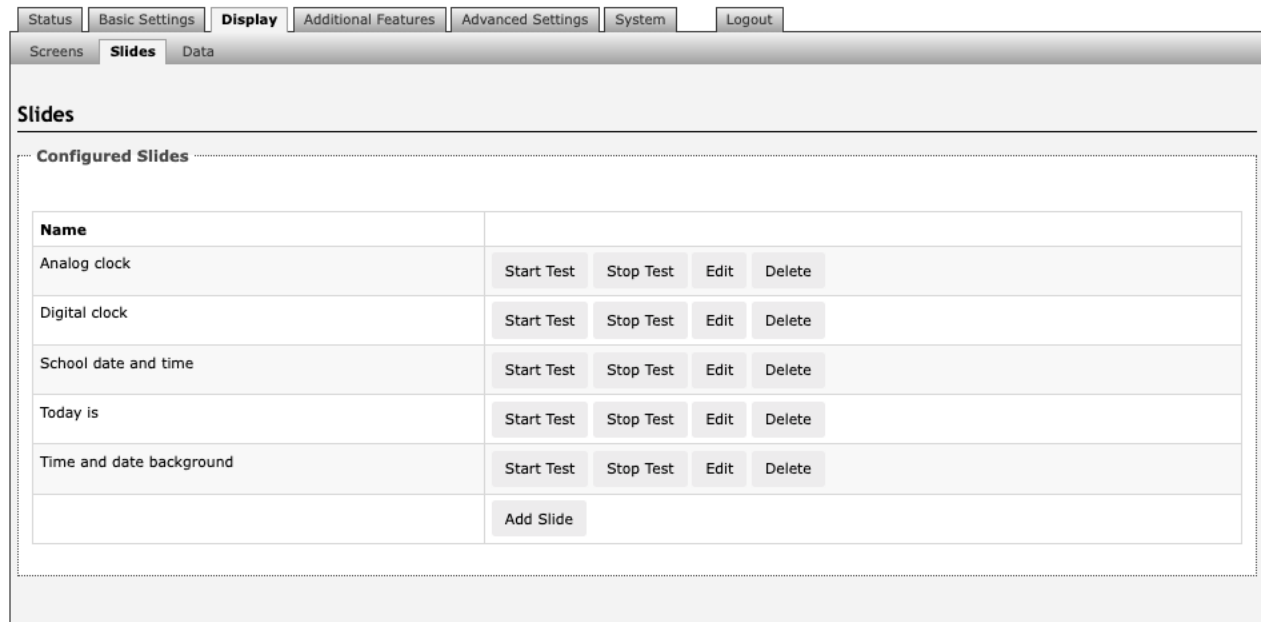

Edit preconfigured slides or add new slides to customize your experience using the 8410 with your company's branding.

Add Slides

Press **Add Slide** to create a new slide based on preconfigured templates. Slide types may include an analog or digital clock display, a new template for notifications or alerts.

Clock

The digital clock setting allows you to change background and font colors.

Template

Choose a template for your Slide based on the purpose. This can include emergency alerts, notifications, weather warnings, or event updates.

5.5.3 Data

Status Basic Settings **Display** Additional Features Advanced Settings System Logout

Screens Slides **Data**

Data

Files

Download image files from the Algo Server Image files can be downloaded manually from [the Algo website](#).

Backup / Restore Data

Download Slide Data File

Restore Slide Data File No file chosen

Clear All Data

Download Image Files from Algo Server

Downloads the factory images from the Algo Server (internet connection is required).

Download Slide Data File

Allows an image to be downloaded and stored for backup purposes. Note that this backup is independent from the rest of the configuration backup on the device.

Restore Slide Data File

Upload and restore a saved slide data file.

Clear All Data

This clears all the slide data, including saved slides.

5.6 Additional Features

5.6.1 Input/Output

The *Input* tab allows external accessories to be connected to the 8410 or 8420. This is a dry contact input which can be configured as ‘normally open’ or ‘normally closed’ mode. Algo offers accessories, such as the 1202, 1203, 1204, and 2507. Third-party accessories/systems may also be used provided they have a dry contact output.

The screenshot displays the 'Input' configuration page with the following sections:

- General:**
 - Relay Input Mode:
 - Disabled
 - Relay Normally Open
 - Relay Normally Open with Supervision (e.g. Algo 1203 Call Switch)
 - Relay Normally Closed
 - Relay Normally Closed with Supervision
 - Mute Switch
 - Mute Switch with Supervision
 - Algo 1202 Call Button
 - Algo 1204 Volume Control Switch (Local or Remote)
 - Algo 1204 Volume Control Switch with Supervision (Local or Remote)
 - Algo 2507 Ring Detector
- Action When Input Triggered:**
 - Action:
 - Play Tone
 - Make SIP Voice Call
 - Make SIP Call with Tone
 - Stream Mic Audio

Play Tone will play a recorded audio file to a local speaker and multicast if configured. *Stream Mic Audio* will stream microphone audio to multicast only, so it requires Multicast "Transmitter" mode to be enabled in "Basic Settings > Multicast".
 - Tone/Pre-recorded Announcement:
 - Tone Duration:
 - Play Once
 - Play While Held
 - Play Until Completion
- Action When Tamper Detected:**
 - Wiring Fault Supervision Mode:
 - Detect Open Circuit Fault Only
 - Detect Both Open Circuit & Short Circuit Faults

*Open Circuit detection will trigger when the current draw is <4mA. Short Circuit detection will trigger when the current draw is >36mA. The nominal source voltage on the Relay Input circuit is 13V, with a 40mA current limit.
 - Action:
 - Play Tone
 - Make SIP Voice Call
 - Make SIP Call with Tone

Play Tone will play a recorded audio file to a local speaker and multicast if configured. *Stream Mic Audio* will stream microphone audio to multicast only, so it requires Multicast "Transmitter" mode to be enabled in "Basic Settings > Multicast". Note that this action will occur 5 seconds after a wiring fault is detected. If the fault is resolved within 5 seconds, this action will not occur.
 - Tone/Pre-recorded Announcement:
 - Tone Duration:
 - Play Once
 - Play While Held
 - Play Until Completion
- Tone Multicast Settings:**
 - Use Separate Multicast:
 - Enabled
 - Disabled

*This will allow the tone to be played via multicast even if the device is configured as a receiver.

A **Save** button is located at the bottom right of the form.

Figure 6: Input settings

General

Relay Input Mode

The input relay to the 8410 and 8420 can be activated by any normally open or normally closed switch. Algo offers the 1202 Call Button, the 1203 Call Switch, or 1204 Volume Control Switch. Via supervision settings, notification actions can also be triggered if the input switch is disconnected.

1203 Call Switch

The 1203 Call Switch is a simple contact closure switch with an illuminated button and supervision capabilities. When used in conjunction with the 8410, the 1203 can prompt a single action with one-touch, or a continuous action if the button is held.



Figure 7: 1203 Call Switch

Mute Switch

Apply an external switch (short-circuit) across the Relay Input terminals in order to mute the 8410 or 8420. This allows a temporary "disable" switch to control the device if desired, for example in a boardroom to block paging during important meetings.

Leave the Relay Input terminals open (no-connect) for regular full-volume operation when in this mode.

Multicast Override

Allow selected multicast zones to override the Mute Switch settings for the selected zones.

1202 Call Button

The 1202 Call Button is a one-touch button for event notification and response. It can be used with the 8410 for improved customer service, emergency notification, and non-emergency alerting. The Call Button's one-touch button can trigger a single or continuous action, which can be halted via the small cancel/reset button located below the main call button.



Figure 8: 1202 Call Button – the insert card is interchangeable

While the 8410 and 8420 can be configured to play the audio file only once, it can also be enabled to play it continuously with just a press of the 1202 Call Button. The action can then be stopped via the smaller oval cancel button located below the main call button on the 1202 Call Button.

1204 Volume Control

The 1204 Volume Control Switch is a simple two terminal potentiometer that will allow attenuation below the maximum volume level (configured under *Basic Settings* → *Features*).



Figure 9: 1204 Volume Control

Mute On Lowest Setting

Enabling 'Mute On Lowest Setting' allows audio to be completely muted when volume control switch is turned all the way down.

Wire Length

This allows you to calibrate impedance for 24 AWG.

Multicast Override

Multicast Override allows selected multicast zones to override the 1204 Volume Control settings for the selected zones.

Remote Volume Settings

Configure the device to subscribe to remote 1204 volume input or to notify remote devices of 1204 volume input.



Note

RESTful API must be enabled in the Advanced Settings → *Admin tab*.

Notify (Local 1204) → remote device RESTful API password

Subscribe (Remote 1204)

- IP address
- Remote device RESTful API password

Action When Input Triggered

Action

Play Tone

When the 8410/8420 input is triggered, a tone or a pre-recorded audio file will play over the speaker or multicast if enabled. This function can be used to request support/assistance in service or retail environments, notify about an emergency at a specific location in medical or educational facilities, or sound an alarm during an intrusion.

- Action When Input Triggered:

- Tone/Pre-recorded Announcement
- Tone Duration

Make SIP Voice Call

When the 8410/8420 input is triggered, a voice path will open for an intercom-like call via an external microphone to a pre-configured phone extension. This option can be used when a call needs to be made from a public place where a phone would not be practical to use.

- Action When Input Triggered:
 - Extension to Dial
 - Call Mode
 - Allow 2nd Button Press
- Outbound SIP Call Settings:
 - Outbound Ring Limit
 - Ringback Tone
 - Maximum Call Duration

Make SIP Call with Tone

When the 8410/8420 input is triggered, a private call can be generated to a pre-configured phone extension with a pre-recorded message. For instance, a call to a supervisor's phone notifying about an emergency or intrusion at some location.

- Action When Input Triggered:
 - Extension to Dial
 - Allow 2nd Button Press
 - Tone/Pre-recorded Announcement
 - Interval Between Tones (seconds)
 - Maximum Tone Duration
- Outbound SIP Call Settings:
 - Outbound Ring Limit

Allow 2nd Button Press

If enabled, the 2nd button press will either simply End Call or End and Restart Call. Therefore, if an input is triggered for the second time the SIP call will either simply be terminated or terminated and immediately called again.

Action When Tamper Detected (Supervision)

In addition to the main events, the device can be configured with supervision to also execute one of the above three actions ('Play Tone', 'Make Two-Way SIP Voice Call', 'Make SIP Call with Tone') in case the device goes offline due to wiring failure or after being tampered with. For example, a tone could sound over the speaker(s), or a private pre-recorded message could be sent to a specified phone extension. The supervision configuration options will appear once a relay option with supervision is selected. See the Electrical Specification section for details on supervision detection circuit.

Wiring Fault Supervision Mode

Short circuit detection will be triggered when the current draw is <4 mA. Short circuit detection will trigger when the current draw is >36 mA. The nominal source voltage on the Relay Input circuit is 13 V, with 40 mA current limit.

Action

“Play Tone” will play a recorded audio file to a local speaker and multicast if configured. “Stream Mic Audio” will stream microphone audio to multicast only, so it requires multicast “Transmitter” mode to be enabled in *Basic Settings* → *Multicast*.



Note

This action will occur 5 seconds after a wiring fault is detected. If the fault is resolved within 5 seconds, this action will not occur.

- Play Tone
- Make SIP Voice Call
- Make SIP Call with Tone

Tone/Pre-recorded Announcement (Action – Play Tone / Make SIP call with Tone)

Select a recording or tone to use. Custom audio files may be used and uploaded through *System* → *File Manager*.

Extension to Dial (Action – Make SIP Voice Call)

SIP account required in Page Extension fields in order to make a call. Can be configured if ‘Make SIP Voice Call’ or ‘Make SIP Call with Tone’ actions are enabled under ‘Call Button Settings’.

Interval Between Tones (Action – Make SIP call with Tone)

Specify the time delay (seconds) between tones. Can be configured if ‘Play Tone’ or ‘Make SIP Call with Tone’ actions are enabled under ‘Call Button Settings’.

Maximum Tone Duration (Action – Play Tone / Make SIP call with Tone)

Select the maximum tone duration. The tone will be terminated once the maximum time is reached. Can be configured if ‘Play Tone’ or ‘Make SIP Call with Tone’ actions are enabled.

Tone Multicast Settings

Use Separate Multicast

This allows the tone to be played via multicast even if the 8410/8420 is configured as receiver. See additional options when enabled.

- Multicast Mode
- IP Address
- Port

Outbound SIP Call Settings

Outbound Ring Limit

Typically set to ensure that a call will not reach voicemail. This feature, under 'Outbound SIP Call Settings', can be used to set a limit on how long the speaker will ring before timing out.

Ringback Tone

If enabled, under 'Outbound SIP Call Settings', a ringback tone will play over the speaker during an outbound SIP call, while waiting for the far-end party to answer.

5.6.2 Emergency Alerts

Status
Basic Settings
Display
Additional Features
Advanced Settings
System
Logout

Click to go back, hold to see history More Page Extensions More Ring Extensions

Emergency Alerts

i This section allows pre-recorded announcements to be triggered & latched by calling an extension and hanging up. The announcement will continue to play until a different "Cancel" extension is called to clear the announcement (or a pre-defined timeout is reached). This can be useful for emergency notifications (e.g. "Evacuation Alert"), allowing staff to quickly dial a pre-configured number and then exit the building. Audio files can be easily uploaded to create custom announcements.

i Up to 10 extensions can be registered allowing up to 10 different announcements. A single "Cancel" extension also needs to be registered; calling this number will cancel the currently active announcement.

i Note: Some SIP phone systems may not support this feature if they limit the number of extensions that can be registered on a single device.

Settings

Default Announcement Duration	<input type="radio"/> Play Once <input checked="" type="radio"/> Play Until Cancelled
Default Maximum Announcement Time	<input type="text" value="10 minutes"/>
Announcement Selection Mode	<input checked="" type="radio"/> Direct Extensions <input type="radio"/> DTMF Selectable <i>i</i> Use "Direct Extensions" to register a separate extension for each announcement. Use "DTMF Selectable" to register a single extension that accepts DTMF input to select which announcement to play.
Answer Inbound Call	<input type="radio"/> Enabled <input checked="" type="radio"/> Disabled <i>i</i> This option selects how the Announcement calls are handled. In both cases, the Emergency Announcement is started when the appropriate extension is called and continues until the Cancel Extension is called. <i>i</i> Select "Enabled" to answer the inbound call and provide the option to play a confirmation tone before starting the alert, then automatically release the call. <i>i</i> Select "Disabled" to detect just the inbound Ring signal, but not actually answer the call
Passcode Protected Announcement Extensions	<input type="radio"/> Enabled <input checked="" type="radio"/> Disabled
Announcement Passcode	<input type="text" value=""/> <i>i</i> Require the caller to enter a passcode after dialing an announcement or call-to-cancel extension. Setting a passcode helps prevent unintentional announcements. When prompted, the caller must enter the passcode followed by the # sign before the announcement will be played or canceled. The passcode prompt will be played before any other action. If the passcode is not correctly entered within 15 seconds, the call will be ended.
Passcode Prompt Tone	<input type="text" value="<Default>"/>

DTMF Selection

Extension	<input type="text"/>
Authentication ID	<input type="text"/>
Authentication Password	<input type="text"/>
Display Name (Optional)	<input type="text"/>
Realm	<input type="text"/>
Prompt Tone	<input type="text" value="<Default>"/>

Call-to-Cancel

Call-to-Cancel Selection Mode	<input checked="" type="radio"/> Direct Extension <input type="radio"/> DTMF 0 <i>i</i> If using "DTMF 0", dial the main DTMF Selection extension and select 0 to cancel the announcement.
Extension	<input type="text"/>
Authentication ID	<input type="text"/>
Authentication Password	<input type="text"/>
Display Name (Optional)	<input type="text"/>
Realm	<input type="text"/>
Confirmation Tone	<input type="text" value="<None>"/>

Announcements

Announcement 10	<input type="radio"/> Enabled <input checked="" type="radio"/> Disabled <i>i</i> In DTMF mode, use 0 to select this announcement.
-----------------	--

Save

Figure 10: Emergency Alerts

Emergency Alerts allow for an announcement to be triggered and latched by calling a pre-configured Emergency extension and hanging up. Emergency Alerts are useful for emergency notifications (e.g., evacuation, lock down, medical emergency, etc.), allowing staff to quickly dial a pre-configured number under such circumstances.

Settings

Default Announcement Duration

The announcement can be chosen to play once or to play until cancel. 'Play Once' mode will play a single cycle of the chosen tone file, despite of its duration. If 'Play Until Cancelled' is selected, the announcement will continue to play until the "Call-to-Cancel" extension is called to clear the announcement (or a defined timeout is reached).

Default Maximum Announcement Time

This represents the duration for how long the announcement plays for.

Announcement Selection Mode

Use 'Direct Extensions' to register a separate extension for each announcement. Use 'DTMF Selectable' to register a single extension that accepts DTMF input to select which announcement to play.

Answer Inbound Call

This option selects how the Announcement calls are handled. In both cases, the Emergency Announcement is started when the appropriate extension is called and continues until the Cancel Extension is called. Select 'Enabled' to answer the inbound call and provide the option to play a confirmation tone before starting the alert, then automatically release the call. Select 'Disabled' to detect just the inbound Ring signal, but not actually answer the call.

If the 'Answer Inbound Call' option is 'Enabled' the call is auto answered and a configurable confirmation tone is played before starting the alert. If 'Disabled', the alert is triggered just by the inbound ring, without answering the call. (In both instances, the announcement will play until the time limit is reached or the 'Cancel Extension' is called). The auto-answering option can be useful when the caller cannot hear announcement from their location. However, in instances where the call might go to a group/multiple extension(s) (including this device), the auto-answer may intercept that call and prevent it from ringing on other devices.

Passcode Protected Announcement Extensions

When enabled, this setting requires the caller to enter a passcode after dialing an announcement or call-to-cancel extension. Setting a passcode helps prevent unintentional announcements.

Announcement Passcode

When prompted, the caller must enter the passcode followed by the # sign before the announcement will be played or canceled. The passcode prompt will be played before any other action. If the passcode is not correctly entered within 15 seconds, the call will be ended.

Passcode Prompt Tone

Select a tone to play when the passcode is ready to be entered.

DTMF Selection

Extension

This is the SIP extension for the DTMF Selection parameter of the 8410/8420. The device will auto-answer any inbound call received on this extension and provide a voice paging path (and multicast if configured).

Authentication ID

The Authentication ID may also be called Username for some SIP servers and in some cases may be the same as the Ring and/or Page extension.

Authentication Password

This is the SIP password provided by the system administrator for the SIP account.

Display Name (Optional)

Enter a 'Display Name' that will be sent when the SIP call is made. The PBX and phone(s) will have to be configured to display this message as the Caller ID.

Prompt Tone

Select a tone to play when the passcode is ready to be entered.

Call-to-Cancel

Call-to-Cancel Selection Mode

If using "DTMF 0", dial the main DTMF Selection extension and select '0' to cancel the announcement.

Extension

This is the SIP extension for the Call-to-Cancel Selection parameter of the 8410. The device will auto-answer any inbound call received on this extension and provide a voice paging path (and multicast if configured).

Authentication ID

The Authentication ID may also be called Username for some SIP servers and in some cases may be the same as the Ring and/or Page extension.

Authentication Password

The SIP password is provided by the system administrator for the SIP account.

Display Name (Optional)

Enter a 'Display Name' that will be sent when the SIP call is made. The PBX and phone(s) will have to be configured to display this message as the Caller ID.

Prompt Tone

Select a tone to play when the passcode is ready to be entered.

Announcements

Announcement 1

To configure an emergency alert extension, select 'Enable' beside the target announcement and enter the Extension, Authentication ID, and Authentication password.

Up to 10 extensions can be registered allowing up to 10 different announcements. Audio files can also be easily uploaded to create custom announcements. Only one 'Call-to-Cancel' extension is needed, despite the number of the alert extensions.

**Note**

Some SIP phone systems may not support this feature if they limit the number of extensions that can be registered on a single device.

Announcement Duration

Choose how long to allow for the announcement duration. An announcement can:

- Play Once
- Play Until Cancelled
- Default

Extension

This is the SIP extension for the Call-to-Cancel Selection parameter of the 8410. The device will auto-answer any inbound call received on this extension and provide a voice paging path (and multicast if configured).

Authentication ID

The Authentication ID may also be called Username for some SIP servers and in some cases may be the same as the Ring and/or Page extension.

Authentication Password

The SIP password is provided by the system administrator for the SIP account.

Display Name (Optional)

Enter a 'Display Name' that will be sent when the SIP call is made. The PBX and phone(s) will have to be configured to display this message as the Caller ID.

5.6.3 More Page Extensions

More Page Extensions

This section allows dedicated extensions to be registered for each paging zone. This provides an alternative to the "DTMF Selectable Zone" option, thus allowing any zone to be called directly without the need to enter DTMF. Depending on the features available on your SIP phone system, this can provide benefits in allowing speed-dial keys to be programmed on user phones for paging a particular zone more easily, or dialing restrictions could potentially be used to allow only selected phones to access certain zones. This feature requires several SIP extensions to be registered with the SIP phone system.

- The 8410 will auto-answer any inbound calls received on these numbers and provide a voice paging path and multicast if configured. Note that only a single call can be active at a time.
- Note: Some SIP phone systems may not support this feature if they limit the number of extensions that can be registered on a single device.
- Multicast Zone Definitions can be found in "Advanced Settings > [Advanced Multicast](#)".

Basic Extensions

Page Extension 2	<input checked="" type="radio"/> Enabled <input type="radio"/> Disabled
Extension	<input type="text"/>
Authentication ID	<input type="text"/>
Authentication Password	<input type="password"/>
Display Name (Optional)	<input type="text"/>
Screen Pattern	<Use Default Screen Pattern>
Page Extension 3	<input type="radio"/> Enabled <input checked="" type="radio"/> Disabled
Page Extension 4	<input type="radio"/> Enabled <input checked="" type="radio"/> Disabled
Page Extension 5	<input type="radio"/> Enabled <input checked="" type="radio"/> Disabled
Page Extension 6	<input type="radio"/> Enabled <input checked="" type="radio"/> Disabled
Page Extension 7	<input type="radio"/> Enabled <input checked="" type="radio"/> Disabled
Page Extension 8	<input type="radio"/> Enabled <input checked="" type="radio"/> Disabled
Page Extension 9	<input type="radio"/> Enabled <input checked="" type="radio"/> Disabled
Page Extension 10	<input type="radio"/> Enabled <input checked="" type="radio"/> Disabled

Save

Figure 11: More page extensions

Additional SIP extensions can be registered for each multicast zone that will be used. This allows the advantage of dialing directly to a zone without needing to enter DTMF Codes (e.g., speed-dial keys can be used), but this may require additional SIP licenses depending on the SIP provider.

To configure additional page extensions (up to 50), select 'Enable' beside the target extension and enter the Extension, Authentication ID, and Authentication password.

The 8410/8420 will auto-answer any inbound calls received on these numbers and provide a voice paging path and multicast if configured. Only a single call can be active at a time.



Note

Some SIP phone systems may not support this feature if they limit the number of extensions that can be registered on a single device.

5.6.4 More Ring Extensions

Figure 12: More ring extensions - screen options

Up to 10 SIP Ring extensions can be registered. To configure additional ring extensions, select 'Enable' beside the target extension and enter the Extension, Authentication ID, and Authentication Password. A unique Ring Tone and Multicast Zone can be assigned to each extension if desired.

Default Screen

Select a default screen to display during a ring.

5.7 Advanced Settings

5.7.1 Network

Status
Basic Settings
Display
Additional Features
Advanced Settings
System
Logout

Network
Admin
Users
Time
Provisioning
Advanced Audio
Advanced SIP
Advanced Multicast

Network Settings

Common

Internet Protocol IPv4 only ▾

DNS Servers
Use space, comma, or semicolon to separate multiple DNS servers, e.g. 192.168.1.10, 192.168.1.11

IPv4

IPv4 Method Static DHCP

IPv4 Address/Netmask
Address (dot delimited)/Netmask (CIDR), e.g. 192.168.1.23/24

IPv4 Gateway

802.1Q Virtual LAN

VLAN Mode None Manual Auto

VLAN ID
Value range: 0 to 4094

VLAN Priority
Value range: 0 to 7

802.1X Port-based Network Access Control

802.1X Authentication Enabled Disabled

Authentication Mode EAP-PEAP/MSCHAPv2 ▾
In EAP-TLS mode, if the authentication server requires devices to be authenticated, a PEM file containing both a device certificate and a private key can be installed on the Algo device. Use the "System > File Manager" tab to upload a Base64 encoded X.509 certificate file renamed to 'client8021x.pem' in the 'certs' folder.

Anonymous ID

ID

Password

Validate Server Certificate Enabled Disabled
Validate the authentication server against common authorities. To validate against additional certificates, use the "System > File Manager" tab to upload a Base64 encoded X.509 certificate file in .pem, .cer, or .crt format to the 'certs/trusted' folder.

Differentiated Services

SIP (6-bit DSCP value)
Valid values range from 0 to 63

RTP (6-bit DSCP value)
Valid values range from 0 to 63

RTCP (6-bit DSCP value)
Valid values range from 0 to 63

DNS

DNS Caching Mode Disabled SIP All
In "SIP" mode, only the results of DNS queries for SIP requests will be cached. In "All" mode, the results of all DNS queries will be cached.

Save

Figure 13: Network settings

Common

Internet Protocol

DHCP is an IP standard designed to make administration of IP addresses simpler. When selected, DHCP will automatically configure IP addresses for each 8410 or 8420 on the network. Alternatively, the 8410/8420 can be set to a static IP address.

DNS Servers

Add one or multiple DNS servers. Separate each server by a space, comma, or semicolon.

IPv4

IPv4 Method

The 8410/8420 can be set to a DHCP or a static IP address. When DHCP is selected, the DHCP will automatically configure IP addresses for each 8410 IP Display Speaker or 8420 IP Dual-Sided Display Speaker on the network.

IPv4 Address/Netmask

Enter the static IP address and netmask (CIDR format) for the 8410/8420 (e.g., 192.168.1.23/24).

IPv4 Gateway

Enter the gateway address.

802.1Q Virtual LAN

VLAN Mode

Enables or Disables VLAN Tagging. VLAN Tagging is the networking standard that supports Virtual LANs (VLANs) on an Ethernet network. The standard defines a system of VLAN tagging for Ethernet frames and the accompanying procedures to be used by bridges and switches in handling such frames. The standard also provides provisions for a quality-of-service prioritization scheme commonly known as IEEE 802.1p and defines the Generic Attribute Registration Protocol.

VLAN ID

Specifies the VLAN to which the Ethernet frame belongs. A 12-bit field specifying the VLAN to which the Ethernet frame belongs. The hexadecimal values of 0x000 and 0xFFF are reserved. All other values may be used as VLAN identifiers, allowing up to 4094 VLANs. The reserved value 0x000 indicates that the frame does not belong to any VLAN; in this case, the 802.1Q tag specifies only a priority and is referred to as a priority tag. On bridges, VLAN 1 (the default VLAN ID) is often reserved for a management VLAN; this is vendor specific.

VLAN Priority

Sets the frame priority level. Otherwise known as Priority Code Point (PCP), VLAN Priority is a 3-bit field which refers to the IEEE 802.1p priority. It indicates the frame priority level. Values are from 0 (lowest) to 7 (highest).

802.1X Port-based Network Access Control

802.1x Authentication

Credentials to access LAN or WLAN that have 802.1X network access control (NAC) enabled. This information will be available from the IT Administrator.

Authentication Mode

Select the desired authentication mode.

Anonymous ID

If configured, the 8410/8420 will send the anonymous ID to the authenticator instead of the 802.1X client username.

ID

The ID should contain a string identifying the IEEE 802.1X authenticator originating the request.

Password

Enter the password.

Validate Server Certificate

Validate the authentication server against common authorities. To validate against additional certificates, go to the *System* → *File Manger* to upload a Base64 encoded X.509 certificate file in .pem, .cer, or .crt format to the 'certs/trusted' folder.

Differentiated Services

This provides quality of service if the DSCP protocol is supported on your network. The Differentiated Services can be specified independently for SIP control packets versus RTP and RTCP audio packets.

SIP (6-bit DSCP value)

Enter the DSCP value for SIP packets.

RTP (6-bit DSCP value)

Enter the DSCP value for RTP packets.

RTCP (6-bit DSCP value)

Enter the DSCP value for RTCP packets.

DNS

DNS Caching Mode

In "SIP" mode, only the results of DNS queries for SIP requests will be cached. In "All" mode, the results of all DNS queries will be cached.

5.7.2 Admin

Status
Basic Settings
Display
Additional Features
Advanced Settings
System
Logout

Network
Admin
Users
Time
Provisioning
Advanced Audio
Advanced SIP
Advanced Multicast

Admin Settings

Admin Password

Old Password	<input type="password"/>
Password	<input type="password"/>
Confirmation	<input type="password"/>

General

Device Name (Hostname)	<input type="text" value="displayspk-18000f"/>
Introduction Section on Status Page	<input checked="" type="radio"/> On <input type="radio"/> Off
Show Status Section on Status Page when Logged Out	<input checked="" type="radio"/> On <input type="radio"/> Off
Display Switch Port ID on Status Page	<input type="radio"/> On <input checked="" type="radio"/> Off <small>Requires the device to be connected to a switch that supports LLDP or CDP.</small>
Web Interface Session Timeout	<input type="text" value="1 hour"/> <small>Automatically log out web interface after period of inactivity.</small>
Play Tone at Startup	<input checked="" type="radio"/> Enabled <input type="radio"/> Disabled <small>A tone can be played at startup to confirm that the device has booted.</small>

Log Settings

Log Level	<input type="radio"/> Error (Lowest) <input type="radio"/> Notice ("Event") <input checked="" type="radio"/> Info ("SIP") <input type="radio"/> Debug (Highest)
Log Method	<input checked="" type="radio"/> Local <input type="radio"/> Network <input type="radio"/> Both

Management

Web Interface Protocol	<input checked="" type="radio"/> Both HTTP and HTTPS <input type="radio"/> HTTPS Only
Force Strong Password	<input type="radio"/> Enabled <input checked="" type="radio"/> Disabled
Allow Secure SIP Passwords	<input type="radio"/> Enabled <input checked="" type="radio"/> Disabled <small>After enabling this option, it is recommended to re-enter SIP passwords and their corresponding realm to store the passwords securely.</small>

Simple Network Management Protocol

SNMP Support	<input type="radio"/> Enabled <input checked="" type="radio"/> Disabled <small>Download MIB file here.</small>
--------------	---

API Support

RESTful API	<input type="radio"/> Enabled <input checked="" type="radio"/> Disabled <small>Secure API for remote access & control via HTTP. Contact Algo Support for more information</small>
-------------	--

System Integrity

System Integrity Checking	<input type="radio"/> Enabled <input checked="" type="radio"/> Disabled <small>This feature verifies installed system packages to ensure they have not been tampered with. Enabling this feature may cause reboots and upgrades to take 30 seconds longer. Verification results can be found on the Status page.</small>
---------------------------	---

Power over Ethernet

PoE Power Detection
 Automatic (Recommended)
 Force PoE+
 Force PoE++ (Type 3)
 Force PoE++ (Type 4)

Use one of the Forced PoE options only when connected to a power injector that does not automatically negotiate its power capabilities. The power injector must be capable of providing 600mA for PoE+, 600mA per pair for PoE++ Type 3, or 960mA per pair for PoE++ Type 4. Incorrect use of this setting may cause the device to reboot if the power source is not capable of delivering the selected power.

Syn-Apps

SA-Announce Support Enabled Disabled

SA-Announce Server

Leave this field blank to use the server provided by DHCP Option 72.

Local Management Port

InformaCast

InformaCast Support Enabled Disabled

This feature requires a valid license to be activated. Please contact sales@algosolutions.com for assistance.

Microsoft

Microsoft Teams Support Enabled Disabled

Enabling this setting will provision the device via Microsoft's servers. The device reboot will take up to 5 minutes to complete.

ADMP Cloud Monitoring

Enable ADMP Cloud Monitoring Enabled Disabled

This feature requires a valid Account ID. Please contact support@algosolutions.com for assistance.

Save

Figure 14: Admin settings

Admin Password

Old Password

Enter the old password.

Password

Password to log into the 8410/8420 web interface. You should change the default password **algo** to secure the device on the network. If you have forgotten your password, you will need to perform a reset using the **Reset Button** to restore the password (as well as all other settings) back to the original factory default conditions.

For additional password security see “Force Strong Password” below.

Confirmation

Re-enter network admin password.

General

Device Name (Hostname)

Name to identify the device in the Algo Network Device Locator Tool.

Introduction Section on Status Page

Allows the introduction text to be hidden from the login screen.

Show Status Section on Status Page when Logged Out

Use this option if you wish to block access to the status page when logged out. The settings and configurations, on the status page, will be hidden entirely unless you're logged in – this feature is useful when you want only trusted users to view possible sensitive device information.

Display Switch Port ID on Status Page

Enable this option to display the Switch Port ID. This option requires the 8410/8420 to be connected to a switch that supports LLDP or CDP.

Web Interface Session Timeout

Set the maximum period of inactivity after which the web interface will log out automatically.

Play Tone at Startup

A tone can be played at start up to confirm that the device has booted.

Log Settings

Log Level

The Log Level is to be used on the advice of Algo technical support only.

Log Method

Allows the 8410/8420 to write to external Syslog server if the option for external (or both) is selected.

Log Server

If 'Network' or 'Both' is selected this is the address of the Syslog server on the network.

Management

Web Interface Protocol

HTTPS is always enabled on the device. Use 'HTTPS Only' mode to disable HTTP, then requests will be automatically redirected to HTTPS. Also note that since the device can have any address on the local network, no security certificate exists, and thus most browsers will provide a warning when using HTTPS.

Force Strong Password

When enabled, ensures that a secure password is provided for the device's web interface for additional protection. The password requirements are:

- Must contain at least 10 characters
- Must contain at least 1 uppercase character
- Must contain at least 1 digit (0 – 9)
- Must contain at least 1 special character

Allow Secure SIP Password

Allows SIP passwords to be stored in the configuration file in an encrypted format, to prevent viewing and recovery. Once enabled, the SIP 'Realm' field should be entered and all the configured Authentication Password(s) must be re-entered in *Basic Settings* → *SIP*, and any other locations where SIP extensions have been configured, to save the encrypted password(s).

If the Realm is changed at a later time, all the passwords will also need to be re-entered again to save the passwords with the new encryption.

To obtain your SIP Realm information, contact your SIP Server administrator (or check the SIP log file for a registration attempt). The Realms may be the same or different for all the extensions used.

Simple Network Management Protocol

SNMP Support

Additional SNMP support is anticipated for future. The current setting of the 8410/8420 will respond to a simple status query for automated supervision. Contact Algo technical support for more information.

API Support

RESTful API

Secure API for remote access and control via HTTP.

System Integrity

System Integrity Checking

This feature verifies installed system packages to ensure they have not been tampered with by running 'Perform Check'. Enabling this feature may cause reboots and upgrades to take 30 seconds longer. Verification results can be found on the *Status* tab.

Power over Ethernet

PoE Power Detection

Use one of the Forced PoE options only when connected to a power injector that does not automatically negotiate its power capabilities. The power injector must be capable of providing 600 mA for PoE+, 600 mA per pair for PoE++ Type

3, or 960 mA per pair for PoE++ Type 4. Incorrect use of this setting may cause the device to reboot if the power source is not capable of delivering the selected power.

Syn-Apps

SA-Announce Support

Syn-Apps SA-Announce paging application converts unicast streams to multicast and delivers them to the target endpoints. The feature can only be used on the 8410/8420 when Multicast Sender Mode is disabled (set to 'None') in the *Basic Settings* → *Multicast* tab.

SA-Announce Server

Enter the SA-Announce Server to use the Syn-Apps paging feature. To use the server provided by the DHCP Option 72, leave the field blank.

Local Management Port

Enter the local management port for the SA-Announce Server.

InformaCast

InformaCast Support

This feature requires a valid InformaCast license to be activated. Please contact sales@algosolutions.com for assistance.

Microsoft

Microsoft Teams Support

Enabling this setting will provision the device via Microsoft's servers. The device reboot will take up to 5 minutes to complete.

ADMP Cloud Monitoring

Enable ADMP Cloud Monitoring

This feature requires a valid Account ID. Please contact sales@algosolutions.com for assistance.

5.7.3 Users

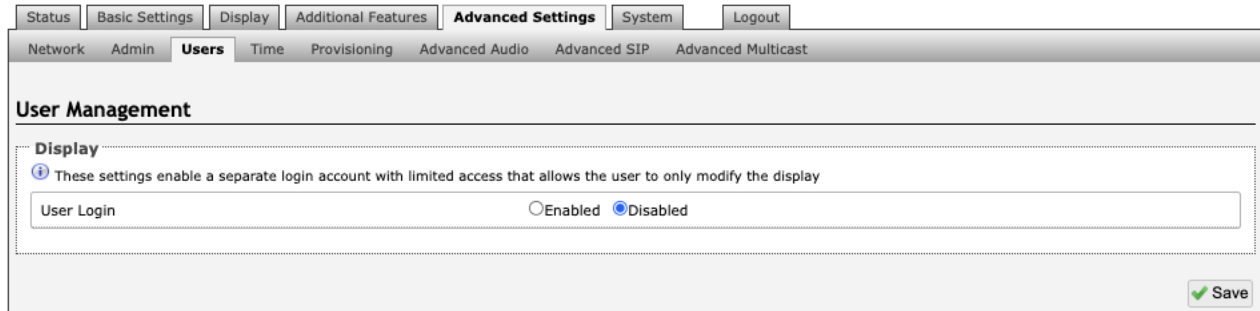

Figure 15: Users settings

A separate login account with limited access can be set up. The user will only be able to modify the device scheduler.

5.7.4 Time

Network time is used for logging events into memory for troubleshooting.

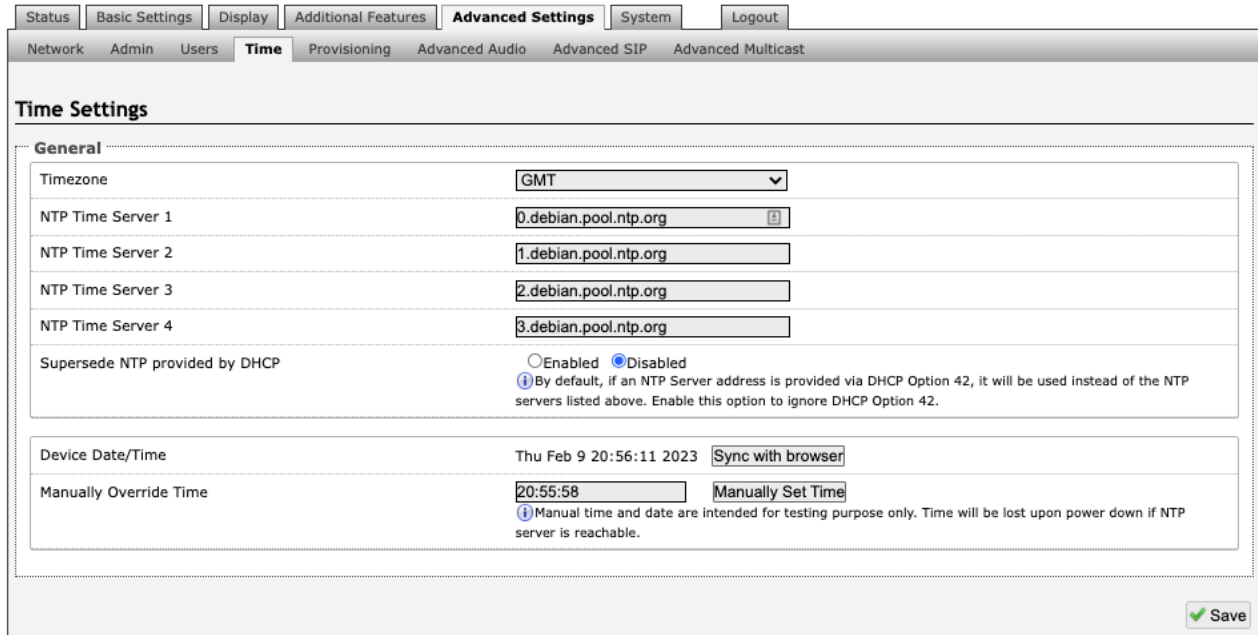

Figure 16: Time settings

Timezone

Select a time zone to be used.

NTP Time Servers 1/2/3/4

The interface will attempt to use Timer Server 1 and work down the list if one or more of the time servers become unresponsive.

Supersede NTP provided by DHCP

When 'Use DHCP Option 42' is chosen, if an NTP Server address is provided via the DHCP Option 42, that NTP Server will be used instead of the four (4) mentioned above. Alternatively, 'Ignore DHCP Option 42' can be chosen to only use servers mentioned above.

Device Date/Time

This field shows the current time and date as set on the device. If testing the device on a lab network that may not have access to an external NTP server, the "Sync with browser" button can be used to temporarily set the time on the device.



Note

This time value will be lost at power down or overwritten if NTP is currently active. Time and date are used for logging purposes and for the scheduler feature.

5.7.5 Provisioning

The screenshot shows the 'Provisioning Settings' page with the following configuration details:

- Mode:** Provisioning Mode is set to Enabled.
- Settings:**
 - Server Method: Static. Note: Auto mode automatically checks all 3 DHCP options for an active provisioning server, in the order listed.
 - Static Server: [Empty text field]
 - Download Method: TFTP.
 - Config Download Path: [Empty text field]
 - Firmware Download Path: [Empty text field]
- Partial Provisioning:** Disabled. Note: Allow support for "-I" incremental provisioning files. Disable for enhanced security if not using this feature.
- Check-sync Behavior:** Always Reboot. Note: If 'Conditional Reboot' is selected, the device will check with the provisioning server and only reboot if new config is found (unless 'reboot=true' is provided as a parameter in the check-sync event).
- Sync Start Time:** [Empty text field]. Note: Schedule a time (HH:mm:ss) for the device to perform a sync according to the 'Check-sync Behavior' option above. Leave blank to disable the feature.
- Sync End Time:** [Empty text field]. Note: If set, the device will sync at a random time in the window between Start Time and End Time. Setting an End Time earlier than Start Time indicates an overnight period. Leave blank to sync at Start Time exactly.
- Sync Frequency:** Selected Days Only.
- Sync Days:** Monday, Tuesday, Wednesday, Thursday, Friday, Saturday, Sunday.
- Zero Touch Provisioning:** Turn Off ZTP. Note: ZTP is disabled and can only be re-enabled with a factory reset.

A green 'Save' button is located at the bottom right of the page.

Figure 17: Provisioning settings



Note

It is recommended that Provisioning Mode be set to Disabled if this feature is not in use. This will prevent unauthorized re-configuration of the device if DHCP is used.

Mode

Provisioning Mode

Provisioning allows installers to pre-configure the 8410/8420 units prior to installation on a network. It is typically used for large deployments to save time and ensure consistent setups.

Settings

Server Method

The device can be provisioned via the Auto mode (where all three DHCP options (Option 66/160/150) will be automatically checked for an active provisioning server), just one of the three specified DHCP options, or a Static Server. In addition, there are four different ways to download provisioning files from a “Provisioning Server”: TFTP (Trivial File Transfer Protocol), FTP, HTTP, or HTTPS.

Static Server

Enter the server address or domain.

Download Method

The 8410/8420 configuration files can be automatically downloaded from a TFTP server using DHCP Option 66. This option code (when set) supplies a TFTP boot server address to the DHCP client to boot from.



Important

DHCP must be enabled if using DHCP Option 66/160/150, in order for Provisioning to work.

One of two files can be uploaded on the Provisioning Server (for access via TFTP, FTP, HTTP, or HTTPS):

- Generic (for all Algo 8410 IP Display Speaker) **algop8410.conf**
- Specific (for a specific MAC address) **algom[MAC].conf**

Both protocol and path are supported for Option 66, allowing for <http://myserver.com/config-path> to be used.

Config Download Path

Enter the path where the configuration file is located within the provisioning server (e.g. algo/config/8410).

Firmware Download Path

Enter the path where the firmware file is located within the provisioning server (e.g. algo/firmware/8410).

Partial Provisioning

Allow support for “-i” incremental provisioning files. Disable for enhanced security if not using this feature.

Check-sync Behavior

If ‘Conditional Reboot’ is selected, the device will check with the provisioning server and only reboot if a new config is found (unless “reboot=true” is provided as a parameter in the check-sync event).

Sync Start Time

Schedule a time (HH:mm:ss) for the device to perform a sync according to the ‘Check-sync Behavior’ option above. Leave blank to disable the feature.

Sync End Time

If set, the device will sync at a random time in the window between Start Time and End Time. Setting an End Time earlier than the Start Time indicates an overnight period. Leave blank to sync at Start Time exactly.

Sync Frequency

Choose the frequency for which this setting should occur. Select between daily or go to 'Sync Days' to choose specific days of the week.

Sync Days

Select the days of the week to apply this setting for.

MD5 Checksum

In addition to the **.conf** file, an **.md5** checksum file must also be uploaded to the Provisioning server (for TFTP mode only). This checksum file is used to verify that the **.conf** file is transferred correctly without error.

A tool such as can be found at the website address below and may be used to generate this file:

<http://www.fourmilab.ch/md5>

The application doesn't need an installation. To use the tool, simply unzip and run the application (md5) from a command prompt. The proper **.md5** file will be generated in the same directory.

If using the above tool, be sure to use the "-l" parameter to generate lower case letters.

Generating a generic configuration file

If using a generic configuration file, extensions and credentials have to be entered manually once the 8410/8420 has automatically downloaded the configuration file.

To see Algo's SIP endpoint provisioning guide, visit: www.algosolutions.com/provision

Generating a Specific Configuration File

The specific configuration file will only be downloaded by the 8410/8420 with the MAC address specified in the configuration file name. Since all the necessary settings can be included in this file, the 8410/8420 will be ready to work immediately after the configuration file is downloaded. The MAC address of each 8410/8420 can be found on the back label of the unit.

To see Algo's SIP endpoint provisioning guide, visit: www.algosolutions.com/provision

5.7.6 Advanced Audio

The screenshot shows the 'Advanced Audio Functions' configuration page. At the top, there are navigation tabs: Status, Basic Settings, Display, Additional Features, **Advanced Settings**, System, and Logout. Below these are sub-tabs: Network, Admin, Users, Time, Provisioning, **Advanced Audio**, Advanced SIP, and Advanced Multicast. The main content area is titled 'Advanced Audio Functions' and is organized into three sections:

- Functions:**
 - Dynamic Range Compression (DRC):** Radio buttons for Enabled and Disabled. 'Disabled' is selected. A help icon indicates: 'Compress the dynamic range of page audio to increase loudness.'
 - Jitter Buffer Range (milliseconds, 10 ~ 500):** A text input field containing '100'. A help icon indicates: 'Adds more buffering if necessary to correct for inconsistent delays on the network. Use of the lowest value generally is recommended.'
 - Always Send RTP Media:** Radio buttons for Enabled and Disabled. 'Enabled' is selected.
- Audio Filters:**
 - Speaker Filter:** A dropdown menu set to 'None'. A help icon indicates: 'Bandwidth also limited by audio codecs.'
 - Speaker Noise Filter:** Radio buttons for Enabled and Disabled. 'Disabled' is selected. A help icon indicates: 'Aggressive 8th order Elliptical Filter (fc = 145Hz)'
 - Microphone Filter:** A dropdown menu set to 'None'.
 - Microphone Noise Filter:** Radio buttons for Enabled and Disabled. 'Disabled' is selected. A help icon indicates: 'Aggressive 8th order Elliptical Filter (fc = 145Hz)'
- Microphone:**
 - Global Microphone Mute:** Radio buttons for Enabled and Disabled. 'Disabled' is selected. A help icon indicates: 'Enabling this will disable the microphone entirely.'
 - Microphone Volume:** A dropdown menu set to 'High'.

A 'Save' button with a green checkmark is located at the bottom right of the form.

Figure 18: Advanced audio settings

Functions

Dynamic Range Compression (DRC)

If enabled, compresses the dynamic range of page audio to increase loudness.

Dynamic Range Compression Gain

Higher compression gain increases distortion.

Jitter Buffer Range

The jitter buffer removes the jitter in arriving network packets by temporarily storing them. This process corrects the inconsistent delays on the network. It is recommended to use the lowest value.

Always Send RTP Media

If enabled, audio packets will be sent at all times, even during one-way paging mode. This option is needed in cases when the server expects to see audio packets at all times.

Audio Filters

Speaker Filter

Applies a high-pass filter to the speaker output. Used to reduce audio artifacts like humming or buzzing by filtering out unwanted frequencies.

Speaker Noise Filter

Enables heavy filtering below 145 Hz to reduce mains induced noise (fans).

Microphone Filter

Applies a high-pass filter to the microphone input. Used to reduce audio artifacts like humming or buzzing by filtering out unwanted frequencies.

Microphone Noise Filter

Enables heavy filtering below 145 Hz to reduce mains induced noise (fans).

Microphone

Global Microphone Mute

Enabling this will disable the microphone entirely.

Microphone Volume

Select a volume for the microphone.

5.7.7 Advanced SIP

Status	Basic Settings	Display	Additional Features	Advanced Settings	System	Logout	
Network	Admin	Users	Time	Provisioning	Advanced Audio	Advanced SIP	Advanced Multicast

Advanced SIP Settings

General

SIP Transportation:
Select Auto to check DNS NAPTR record, then try UDP/TCP.
 In TLS mode, if the SIP Server requires endpoints to be authenticated, a PEM file containing both a device certificate and a private key needs to be installed on the Algo device. Use the "System > File Manager" tab to upload a certificate file renamed to 'sipclient.pem' in the 'certs' folder.

SIPS Scheme: Enabled Disabled

Validate Server Certificate: Enabled Disabled
Validate the SIP server against common certificate authorities. To validate against additional certificates, use the "System > File Manager" tab to upload a Base64 encoded X.509 certificate file in .pem, .cer, or .crt format to the 'certs/trusted' folder.

SIP Outbound Support (RFC 5626): Enabled Disabled
Only enable this option if the SIP server supports RFC 5626.

Outbound Proxy:

Register Period (seconds):

SRTP

SDP SRTP Offer:

NAT

Media NAT: None ICE STUN

TURN Server:

TURN User:

TURN Password:

Server Redundancy

Server Redundancy Feature (Multiple SIP Server Support): Enabled Disabled

Backup Server #1:

Backup Server #2:

Polling Interval (seconds):
Time to wait between sending monitoring packets to each server. Inactive servers are always polled and the active server may optionally be polled (see below).

Poll Active Server: Enabled Disabled
Explicitly poll the current server to monitor its availability. Polling may also be handled automatically by other regular events, so this can be disabled to reduce network traffic.

Automatic Failback: Enabled Disabled
Reconnect with a higher priority server once available, even if the backup connection is still working.

Polling Method: SIP NOTIFY SIP OPTIONS
SIP message used to poll servers in order to monitor their availability.

Interoperability

Keep-Alive Method: None Double CRLF
This setting will enable sending periodic CRLF messages for both UDP and TCP connections.

Use Outgoing TLS port in SIP headers: Enabled Disabled
Use ephemeral port number from outgoing SIP TLS connection instead of listening port number in SIP Contact and Via headers. This is useful to connect the device to some local SIP servers, like Asterisk or FreeSWITCH.

Do Not Reuse Authorization Headers: Enabled Disabled
When enabled, all SIP authorization information from the last successful request will not be reused in the next request.

Allow Missing Subscription-State Headers: Enabled Disabled
When enabled, allow SIP NOTIFY messages that do not contain a "Subscription-State" header.

Save

Figure 19: Advanced SIP Setting

General

SIP Transportation

Which transport layer protocol to use for SIP messages. Setting 'SIP Transportation' to 'TLS', ensures the encryption of SIP traffic.

SIPS Scheme

Only visible when 'SIP Transportation' set to 'TLS'. Enabling SIPS Scheme requires the SIP connection from endpoint to endpoint to be secure.

Validate Server Certificate

Validate the SIP server against common certificate authorities.

SIP Outbound Support (RFC 5626)

Enable this option to support best networking practices according to RFC 5626. This option should generally be enabled if the Algo device is being registered with a hosted server or if TLS is being used for SIP Transportation.

Outbound Proxy

IP address for outbound proxy. A proxy (server) stands between a private network and the internet.

Register Period (seconds)

Maximum requested period of time where the 8410/8420 will re-register with the SIP server. Default setting is 3600 seconds (1 hour). Only change if instructed otherwise.

SRTP

SDP SRTP Offer

Setting 'SDP SRTP Offer' to 'Optional', means the SIP call's RTP data will be left unencrypted if the other party does not support SRTP. Setting 'SDP SRTP Offer' to 'Standard', encrypts RTP voice data, meaning the normal audio RTP packets will now be secure (SRTP). This means SIP calls will be rejected if other party does not support SRTP. The 'Standard' option secures the audio data between parties, by making sure that it's not left out in the open for third parties to later reconstruct and listen to.

NAT

Media NAT

IP address for STUN server if present or IP address/credentials for a TURN server.

ICE – TURN Server

Enter the IP address or domain of the ICE server.

ICE – TURN User

Enter the username.

ICE – TURN Password

Enter the password.

STUN - Server

Enter the IP address or domain of the STUN server.

Server Redundancy

Server Redundancy Feature

Two secondary SIP servers may be configured. The 8410/8420 will attempt to register with the primary server but switch to a secondary server when necessary. The configuration allows re-registration to the primary server upon availability or to stay with a server until unresponsive.

If Server Redundancy is selected the web page will expand as shown below.

Backup Server #1

If the primary server is unreachable, the 8410/8420 will attempt to register with the backup servers. If enabled, the 8410/8420 will always attempt to register with the highest priority server.

Backup Server #2

If backup server #1 is unreachable, the 8410/8420 will attempt to register with the 2nd backup server. If enabled, the 8410/8420 will always attempt to register with the highest priority server.

Polling Intervals (seconds)

The time period between sending monitoring packets to each server. Non-active servers are always polled, and active server may optionally be polled (see below).

Poll Active Server

Explicitly poll current server to monitor availability. This may also be handled automatically by other regular events and can be disabled to reduce network traffic.

Automatic Fallback

This enables device to reconnect with a higher priority server once available, even if the backup connection is still fine.

Polling Method

A SIP message used to poll servers to monitor availability.

Interoperability

Keep-Alive Method

If Double CRLF is selected, the 8410/8420 will send a packet every 30 seconds (recommended value) to maintain connection with the SIP Server if behind NAT.

Keep-Alive Interval

This is the interval in seconds that the CRLF message should be sent.

Use Outgoing TLS port in SIP Headers

Use ephemeral port number from outgoing SIP TLS connection instead of the listening port number in SIP Contact and Via headers. This is useful to connect the device to some local SIP servers, like Asterisk or FreeSWITCH.

Do Not Reuse Authorization Headers

When enabled, all SIP authorization information from the last successful request will not be reused in the next request.

Allow Missing Subscription-State Headers

When enabled, this allows SIP NOTIFY messages that do not contain a 'Subscription-State' header.

5.7.8 Advanced Multicast

Advanced Multicast Settings

Current multicast mode: Transmitter
Multicast mode can be set in "Basic Settings > Multicast".

Transmitter Settings

Transmitter Output Codec: G.711 ulaw

Output Packetization Time (milliseconds): 20

Multicast TTL: 1

RTP Control Protocol (RTCP)

RTCP Port Selection: Disabled Next Higher Port Multiplexed on Same Port

Basic Zone Definition

Zone	IP Address and Port	Page Tone
Priority Call (DTMF:9)	224.0.2.60:50000	<Use Default Page Ton
All Call (DTMF:0/8)	224.0.2.60:50001	<Use Default Page Ton
Zone 1 (DTMF:1)	224.0.2.60:50002	<Use Default Page Ton
Zone 2 (DTMF:2)	224.0.2.60:50003	<Use Default Page Ton
Zone 3 (DTMF:3)	224.0.2.60:50004	<Use Default Page Ton
Zone 4 (DTMF:4)	224.0.2.60:50005	<Use Default Page Ton
Zone 5 (DTMF:5)	224.0.2.60:50006	<Use Default Page Ton
Zone 6 (DTMF:6)	224.0.2.60:50007	<Use Default Page Ton
Music (DTMF:7)	224.0.2.60:50008	<Use Default Page Ton

Save

Figure 20: Advanced multicast - transmitter settings



Note

The settings on this tab are only visible when in Sender or Receiver multicast mode.

The default pre-populated multicast addresses above will work in most cases and should only be altered for rare cases.

Transmitter Settings

Transmitter Output Codec

This is the audio encoding format used by the Transmitter device when sending output to the Receivers.

Output Packetization Time (milliseconds)

The size of the audio packets sent by the Transmitter to the Receivers. The default of 20 ms is recommended unless a different value is specifically required for compatibility with other devices.

Multicast TTL

The multicast time to live (TTL) setting should only be changed if custom routing is configured on the network that specifically routes multicast packets between subnets and a longer TTL count is required. This ensures packets are not bounced back and forth in a network identity. When the TTL is reached, the router drops the packet.

Receiver Settings

RTCP Port Selection

Select the port on which RTCP packets will be sent or received. If using the 'Next Higher Port' option, ensure that the default multicast zone definitions are modified such that zones are only assigned to even-numbered ports, leaving the next higher odd-numbered ports free for RTCP packets.

Polycom Receiver Tones

Available if Multicast Receiver and 'Polycom Group Page' or 'Polycom Push-to-Talk' are selected in the *Basic Settings* → *Multicast* tab. A tone may be set for any of the 25 Polycom Groups. If using an Algo device as a Multicast Sender, it is recommended to set the Receiver tones to 'None' to avoid conflicts, as the Algo devices already multicast a tone by default.

Basic Zone Definitions

Zones

The 'Expanded' Receiver zones can be enabled/disabled in *Basic Settings* → *Multicast*. Default IP addresses and ports may be revised for any given zone in the table.



Important

Ensure that the Address and Port settings are the same for all Sender and Receiver devices.

Page Tone and Page Volume

Sender Mode: By default, the same tone can be set for all Receiver zones in the *Basic Settings* → *Features* tab. Unique paging tones may be revised for any given zone in the table above.

Receiver Mode: When an Algo device is the multicast Sender, a page tone will play on the Receiver device, so it is recommended to set the Receiver tone to 'None'. If a page is received from a non-Algo device that doesn't send a tone, a tone can be inserted on the Receivers (above) each time they detect page audio starting, allowing them to play a tone.

By default, the same page volume can be set for all Receiver zones in the *Basic Settings* → *Features* tab. Unique page volumes may be revised on a per-zone basis in the table above. For instance, emergency pages can be louder on certain Receiver speakers.

5.8 System

5.8.1 Maintenance

The screenshot shows the 'System Maintenance' section of the ALGO web interface. At the top, there are navigation tabs: Status, Basic Settings, Display, Additional Features, Advanced Settings, System (selected), and Logout. Below these are sub-tabs for Maintenance: Firmware, File Manager, Tones, System Log, Credits, and About. The main content area is titled 'System Maintenance' and is divided into three sections:

- Backup / Restore Configuration:** Contains three rows of controls:
 - 'Download Configuration File' with a 'Download' button.
 - 'Restore Configuration File' with a 'Choose File' button, 'No file chosen' text, and a 'Restore' button.
 - 'Restore Configuration to Defaults' with a 'Restore Defaults' button.
- Backup / Restore All User Files:** Includes a note: 'Backup in zip format includes configuration file and all uploaded files.' It contains three rows of controls:
 - 'Download Backup Zip File' with a 'Download' button.
 - 'Restore from Backup Zip File' with a 'Choose File' button, 'No file chosen' text, and a 'Restore' button.
 - 'Restore All Settings and Files to Defaults' with a 'Restore Defaults and Delete Files' button. Below this button is a warning icon and text: 'All preloaded and uploaded files, including tone files, will be deleted.'
- Reboot:** Contains one row with 'Reboot the device' and a 'Reboot' button.

Figure 21: Maintenance settings

Backup / Restore Configuration

Download Configuration File

Save the device settings to a text file for backup or to setup a provisioning configuration file.

Restore Configuration File

Restore settings from a backup file.

Restore Configuration to Defaults

Resets all 8410 IP Display Speaker settings to factory default values.

Backup / Restore All User Files

Download Backup Zip File

Saves the device settings (configuration) and all the files in File Manager: certificates, licenses, and tones to a backup zip file.

Restore from Backup Zip File

Restores the device settings (configuration) and all the files in *File Manager*: certificates, licenses, and tones from a backup zip file.

Restore All Settings and Files to Defaults

Resets the device settings (configuration) and all the files in *File Manager*: certificates, licenses, and tones to factory default values.

Reboot

Reboot the Device

Reboots the device.

5.8.2 Firmware

The screenshot shows the 'Firmware' settings page. At the top, there is a navigation bar with tabs: Status, Basic Settings, Display, Additional Features, Advanced Settings, System (selected), and Logout. Below this is a sub-navigation bar with tabs: Maintenance, Firmware (selected), File Manager, Tones, System Log, Credits, and About. The main content area is titled 'Firmware' and contains three sections: 1. 'Installed Firmware' with a text field showing 'algo-8410-5.3_beta3.1'. 2. 'Online Upgrade' with a 'Check for Firmware Updates' label and a 'Check' button. 3. 'Custom Upgrade' with a 'Method' section containing radio buttons for 'From Local Files' (selected) and 'From URL'. Below this is a 'Signed Firmware File' section with a 'Choose File' button and 'No file chosen' text. The 'Allow Downgrade' section has radio buttons for 'Enabled' and 'Disabled' (selected), followed by an information icon and text: 'Allow product or base firmware to be downgraded to an older patch version.' and a warning icon with text: 'Enabling this option could cause upgrade issues. Please contact support if necessary.' At the bottom of the Custom Upgrade section is an 'Upgrade' button.

Figure 22: Firmware settings

Installed Firmware

Product Firmware

Shows the current firmware on the device.

Online Upgrade

Check for Firmware Updates

Check for the latest firmware. If firmware is current, **Latest Firmware** will show as 'Firmware up to date'. If firmware needs to be upgraded, the new firmware availability will be listed.

Custom Upgrade

Method

For firmware upgrades. Specify whether the firmware files will be downloaded from the local computer or a remote URL.

Signed Firmware File

How to upgrade Firmware

1. From the top menu, go to *System* → *Firmware*.
2. In the Upgrade section, press **Choose File** and select the 8410 firmware file to upload. Note that both FW firmware and MD5 checksum files must be loaded.
3. Press **Upgrade**.
4. After the upgrade is complete, confirm that the firmware version has changed (refer to top right of Control Panel).

Allow Downgrade

Allow product or base firmware to be downgraded to an older patch version. Enabling this option could cause upgrade issues.

5.8.3 File Manager

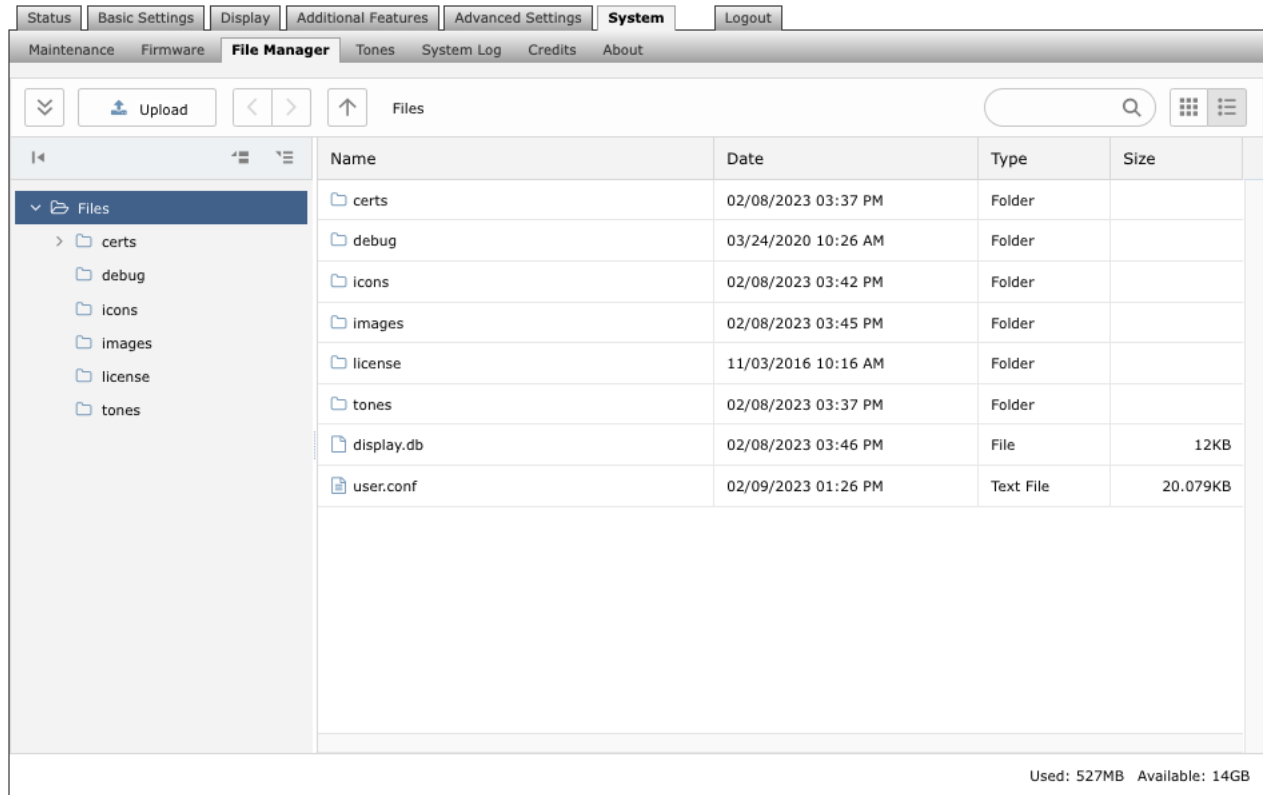

Figure 23: File manager settings

Uploading Custom Audio Files

Custom audio files may be uploaded into memory (1 GB) to play for notification applications. Place your audio files into the **tones** directory.

An existing file may also be modified. Download the original file and right clicking the tone and selecting 'Download', making the desired changes, and then uploading the new version with a different name. Audio files must be in the following format:

- WAV format
- 8 kHz or 16 kHz sampling rate
- 16-bit PCM, or u-law
- Mono
- Smaller than 200 MB

File names must be limited to 32 characters, with no spaces.

For further instructions reference the Custom Tone Conversion and Upload Guide.

5.8.4 Tones

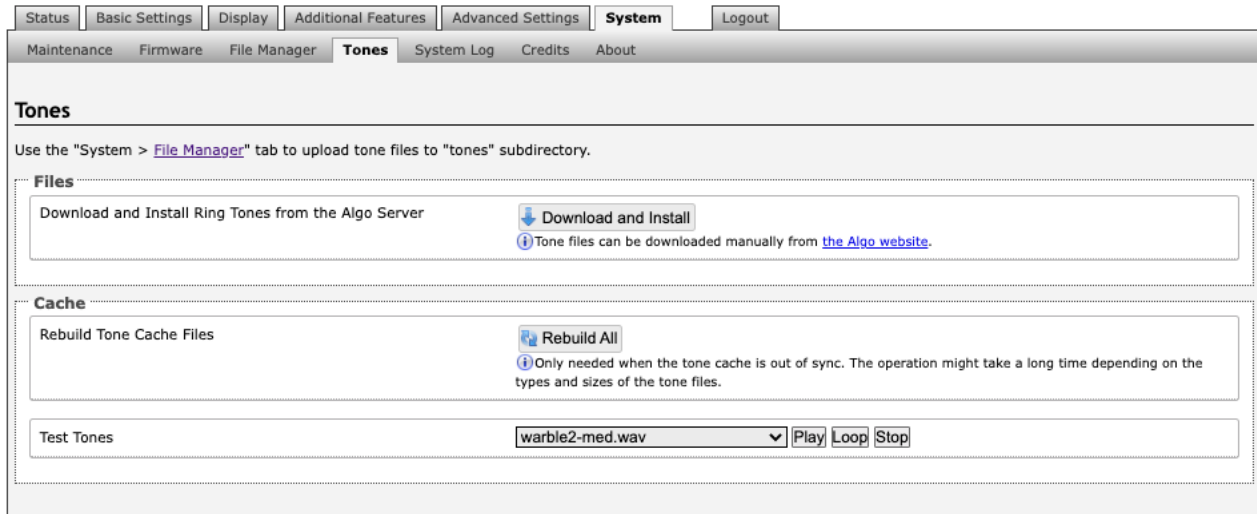

Figure 24: Tones settings

Tone Files Included in Memory

The 8410/8420 includes several pre-loaded audio files that can be selected to play for various events. The web interface allows selection of the file and the ability to play it immediately over the speaker for testing (available in *Basic Settings* → *Features*). Files may also be deleted or renamed.

5.8.5 System Log

System log files are automatically created and assist with troubleshooting in the event the 8410/8420 does not behave as expected.

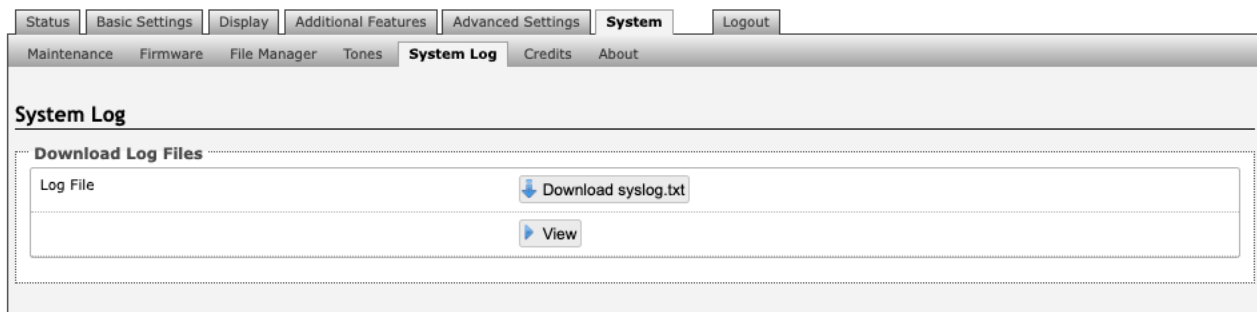

Figure 25: System log settings

5.9 Logout

Log out of the 8410/8420 web interface.

6 SPECIFICATIONS

Table 1: 8410 Specification Table

Power	
PoE-Powered	Recommended: PoE++ (IEEE 802.3bt Type 3 Max 51W) Optional: PoE+ (IEEE 802.3at Type 2 Max 25.5W)
SIP	
SIP Extensions	50 Page & 10 Alerting/Ring extensions with multicast scalability
Transport Protocols	UDP, RTP, TCP
Security	TLS, MTLS, SRTP
Multicast Compatibility	
Multicast	RTP Multicast (Send and Receive 50 Zones)
Third-Party Multicast	PolyTM Group Page, SinglewireTM InformaCast, Syn-AppsTM Revolution
Digital IO	
Relay Configured as Input	Normally open or normally closed dry contact supervision. Compatible with Algo 1202, 1203, and 1204 Accessories.
API	
API	RESTful
Audio	
Audio Codes	G.711 A-law, G.711 u-law, G.722, Opus 48 kHz.
Speakers	3 x Neodymium magnet with polypropylene cone
Frequency Response	150 – 19,000 Hz (- 10 dB)
Driver Sensitivity	92 dBA 1m/1W (1 kHz sine wave)
SPL	Peak 106 dBA/1m
Max Audio Power	8 Watts
Audio Memory + Format	1 GB user space for WAV or MP3 files
Microphone	Omnidirectional – talkback and ambient noise monitoring
Audio Controls	Volume, AGC, Latency, LF Cut
Anti-feedback Delay	Cache to memory and release
Video	
LCD Viewing Area	13.5" x 7.6" (34.4 cm x 19.4 cm)
Resolution	1920 x 1080 @ 60 fps
Viewing Angle	88 deg (horizontal and vertical)
Color	16.7 M
Backlight	LED Auto-dimmable
Contrast	1000:1

Network	
Network	IPv4, IPv6, DHCP, VLAN, MDNS
Link Layer	LLDP, CDP
QOS	DSCP (SIP, RTP, RTCP)
Web Interface	HTTP, HTTPS
Provisioning	TFTP, FTTP, HTTP, HTTPS, DHCP Options 66, 150, 160 Reboot via SIP Check-sync
NAT	STUN, TURN, CRLF Keep Alive, SIP Outbound
Address Resolution	DNS, SRV Record
Supervision	SNMP V1.3, RTCP, Algo 8300, ADMP
Redundancy	Secondary and tertiary SIP server
Environmental & Mechanical	
Environmental	32 to 104 deg F (0 to + 40 degC); 10-95% RH non-condensing. Dry indoor locations only.
Dimensions (Product)	19.5" x 9.5" x 1.75"
Compliance	
IEC 62368-1, IEEE 802.3-2018, RoHS, CE, FCC Class A, CISPR 32 Class A, CISPR 24, CSA/UL (USA & Canada),	
Firmware	
These specifications refer to the Algo 8410 running on firmware 5.2 and above.	

Table 2: 8420 Specification Table

Power	
PoE-Powered	Recommended: PoE++ (IEEE 802.3bt Type 4 Max 71.3) Minimum: PoE+ (IEEE 802.3bt Type 3 Max 51W)
SIP	
SIP Extensions	50 Page & 10 Alerting/Ring extensions with multicast scalability
Transport Protocols	UDP, RTP, TCP
Security	TLS, MTLS, SRTP
Multicast Compatibility	
Multicast	RTP Multicast (Send and Receive 50 Zones)
Third-Party Multicast	PolyTM Group Page, SinglewireTM InformaCast, Syn-AppsTM Revolution
Digital IO	
Relay Configured as Input	Normally open or normally closed dry contact supervision. Compatible with Algo 1202, 1203, and 1204 Accessories.
API	
API	RESTful
Audio	
Audio Codes	G.711 A-law, G.711 u-law, G.722, Opus 48 kHz.
Speakers	6 x Neodymium magnet with polypropylene cone
Frequency Response	150 – 19,000 Hz (- 10 dB)
Driver Sensitivity	92 dBA 1m/1W (1 kHz sine wave)
Maximum SPL	100 dBA/1m
Max Audio Power	12 Watts
Audio Memory + Format	1 GB user space for WAV or MP3 files
Microphone	Omnidirectional – talkback and ambient noise monitoring
Audio Controls	Volume, AGC, Latency, LF Cut
Anti-feedback Delay	Cache to memory and release
Video	
LCD Viewing Area	Two LCD screens of 13.5" x 7.6" (34.4 cm x 19.4 cm)
Resolution	1920 x 1080 @ 60 fps
Viewing Angle	88 deg (horizontal and vertical)
Color	16.7 M
Backlight	LED Auto-dimmable
Contrast	1000:1

Network	
Network	IPv4, IPv6, DHCP, VLAN, MDNS
Link Layer	LLDP, CDP
QOS	DSCP (SIP, RTP, RTCP)
Web Interface	HTTP, HTTPS
Provisioning	TFTP, FTTP, HTTP, HTTPS, DHCP Options 66, 150, 160 Reboot via SIP Check-sync
NAT	STUN, TURN, CRLF Keep Alive, SIP Outbound
Address Resolution	DNS, SRV Record
Supervision	SNMP V1.3, RTCP, Algo 8300, ADMP
Redundancy	Secondary and tertiary SIP server
Environmental & Mechanical	
Environmental	32 to 104 deg F (0 to + 40 degC); 10-95% RH non-condensing. Dry indoor locations only.
Dimensions (Product)	19.5" x 9.5" x 3"
Compliance	
IEC 62368-1, IEEE 802.3-2018, RoHS, CE, FCC Class A, CISPR 32 Class A, CISPR 24, CSA/UL (USA & Canada),	
Firmware	
These specifications refer to the Algo 8410 running on firmware 5.2 and above.	

7 FCC COMPLIANCE STATEMENT

his equipment has been tested and found to comply with the limits for a Class A digital device, pursuant to Part 15 of the FCC Rules. These limits are designed to provide reasonable protection against harmful interference when the equipment is operated in a commercial environment. This equipment generates, uses, and can radiate radio frequency energy, and if it is not installed and used in accordance with the instruction manual, it may cause harmful interference to radio communications. Operations of this equipment in a residential area is likely to cause harmful interference, in which case the user will be required to correct the interference at his or her own expense.